

**ITALSTUDIO**  
THE DESIGN LAB

**ITALSTUDIO**

THE DESIGN LAB

# Italstudio. An international brand created by Italian mind.

Is it possible to give customers from all over the world the creativity, the quality of Italian design at a fair price?

This was my challenge. And this is the mission of Italstudio, a company based in Guangzhou, but using machinery, production techniques

and design exclusively Italian. Thousands of customers all over the world every day let me believe that this challenge is already a big reality of the globalized market.

## FIXED



**Ventaglio** 16-21



**Oxo** 36-39



**Astor** 22-27



**Giovenew** 40-43



**Oberon** 28-31



**Giove** 44-51



**Tritone** 32-35



**Dolmen** 52-55

## EXTENSION



**Tango** 58-61



**Oxo** 76-79



**Tito** 94-97



**Oberon** 62-65



**Uranio** 80-85



**Gemma** 98-101



**Oberon** 66-69



**Dedalo** 86-89



**Titano** 102-107



**Mercurio** 70-75



**Giovinnew** 90-93

# TABLES

## ROUND



**Gemello** 108-111



**Rimini** 114-117



**Prisma** 122-125



**Cassio** 112-113



**Trident** 118-121



**Dolmen** 126-127

## HOME OFFICE



**Traglass** 130-133



**Katie** 138-139



**Soft HO** 142-143



**Trapeze** 134-137



**Rosa** 140-141



**Venice HO** 144-145

# CHAIRS SOFT UPHOLSTERY



**Antina** 148-149



**Altana** 154-155



**Bologna** 160-163



**Anna** 166-167



**Foggia** 174-175



**Maxari** 180-181



**Bonaria** 186-187



**Antina** 150-151



**Marina** 158-159



**Anna soft** 168-171



**Trani** 176-177



**Monica** 182-183



**Sina** 188-189



**Mara** 190-191



**Loge** 152-153



**Loretta** 156-157



**Genova** 164-165



**Barletta** 172-173



**Maxsoft** 178-179



**Alex** 184-185



**Altea** 192-193

# CHAIRS SOFT UPHOLSTERY

# BAR-STOOLS

# ADJUSTABLE STOOLS



**Emma** 194-195



**Lanza** 200-201



**Viola** 2196-197



**Venice** 202-203



**Filotta** 198-199



**Antina** 206-207



**Loge** 208-209



**Loreno** 210-211



**Maxsoft** 212



**Venice** 230-231



**Emma** 232-233



**Filu** 214-215



**Antina** 216-217



**Anteo** 220-221



**Marlon** 227



**Loge** 209



**Alex** 222-223



**Brando** 226-227



**Martino** 218-219



**Elva** 224-225



**Dario** 228-229



**Loreno** 211



**Maxsoft** 213

# OCCASIONAL



**Katie** 236-239



**Otello** 246-247



**Dorio** 252



**Marino** 256-257



**Safari** 262-263



**Treo** 268-269



**Athena** 240-243



**Goccia** 248-249



**Orio** 252-253



**Marino** 258-259



**Ovalino** 264-267



**Duetto** 270-271



**Ovale** 244-245



**Dorio** 250-251



**Orio** 254-255



**Marino** 260-261



**Zibibbo** 272-273

# FIX Tables

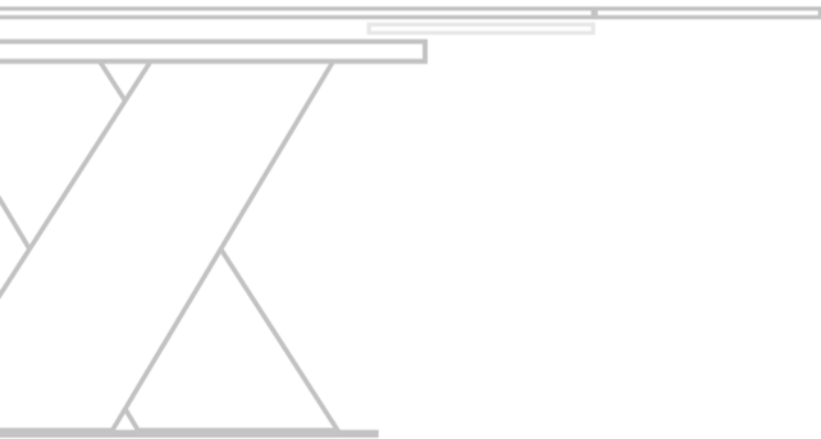

# Tables



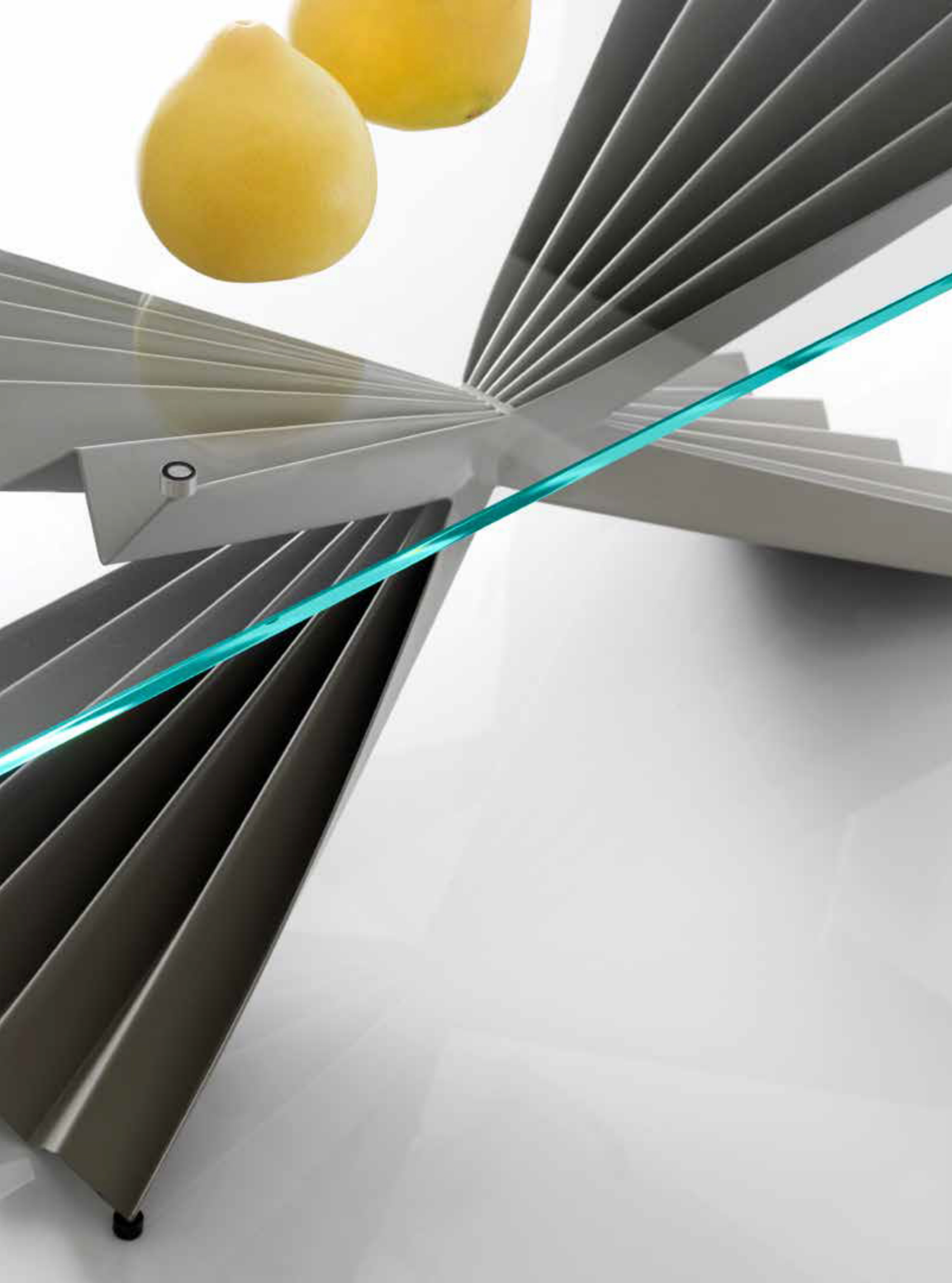

# Ventaglio

DESIGN ARNALDO GAMBA

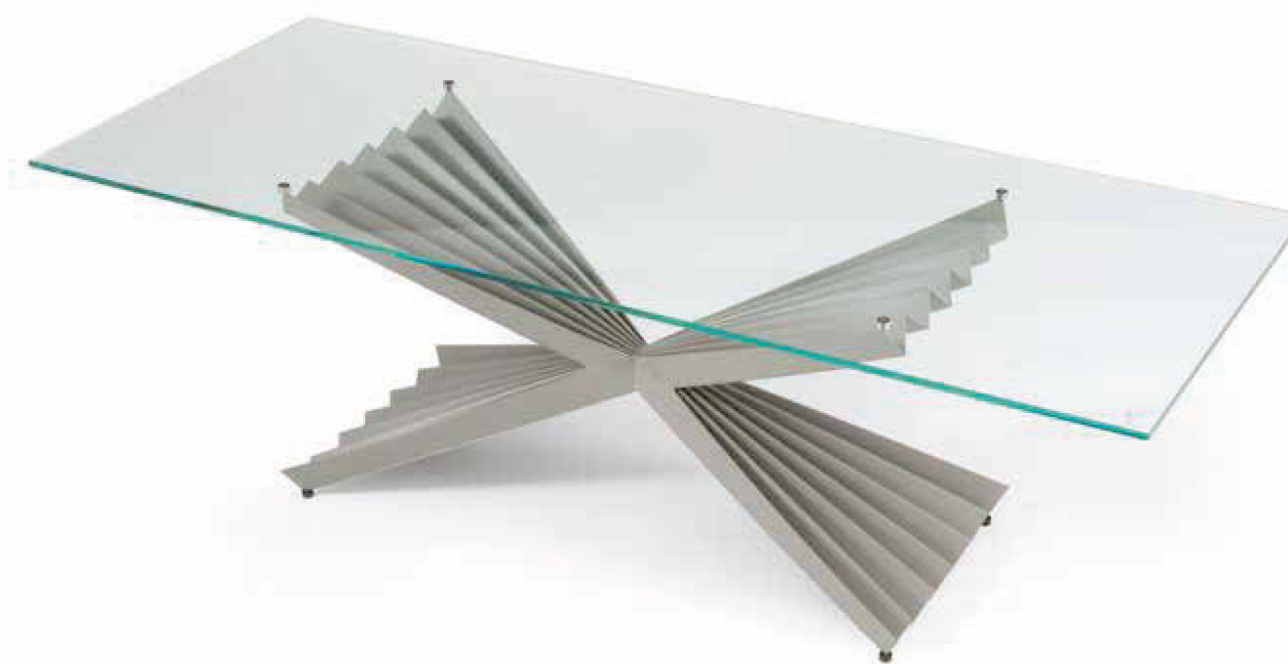

REGISTERED DESIGN:  
CHINA | EUROPE | NORTH AMERICA

# Ventaglio

DESIGN ARNALDO GAMBA

T299 DINING TABLE

FRAME: POWDER COATING

TOP: CLEAR GLASS

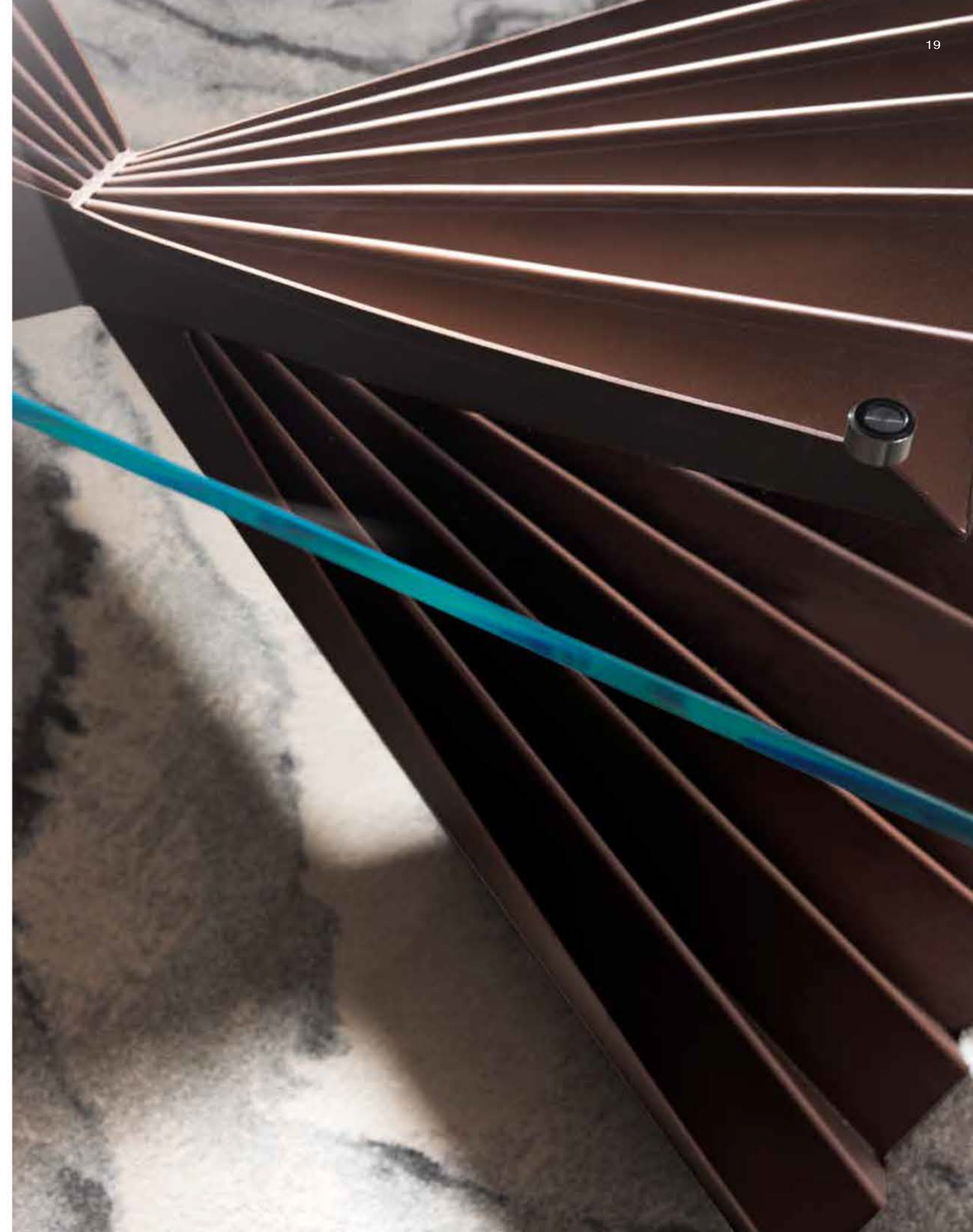
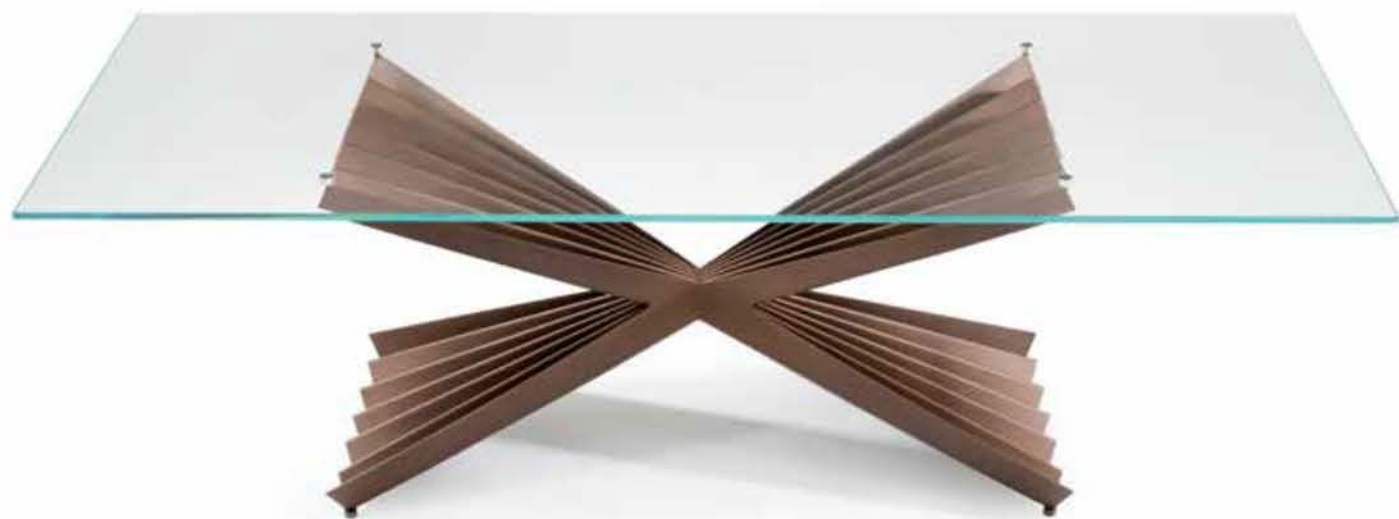
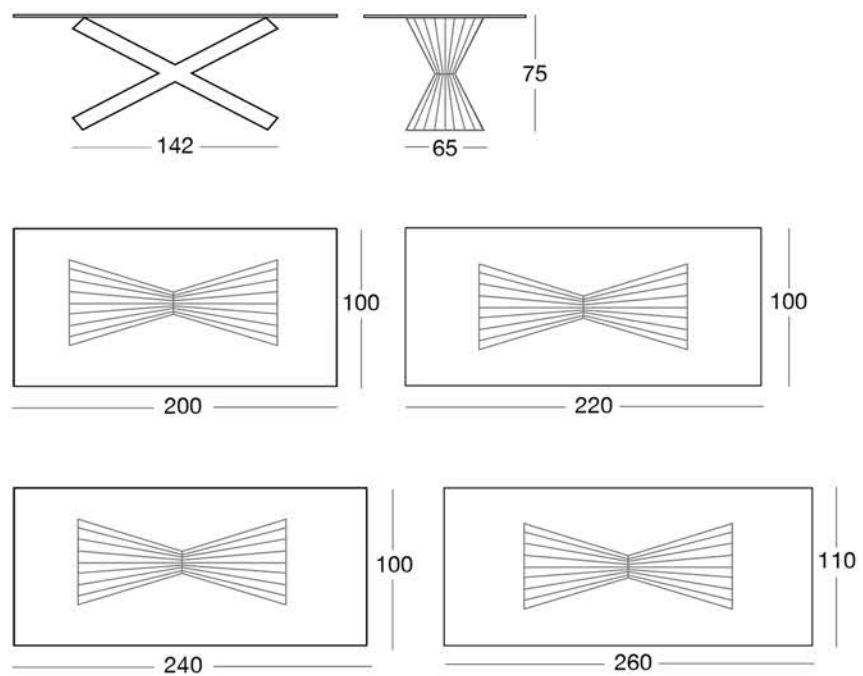





# Astor

DESIGN Y. HATANO



# Astor

DESIGN Y. HATANO

T308 FIXED DINING TABLE

LEGS/FRAME: POWDER COAT

GLASS TOP: PAINTED MATTE

CERAMIC TOP: MATTE

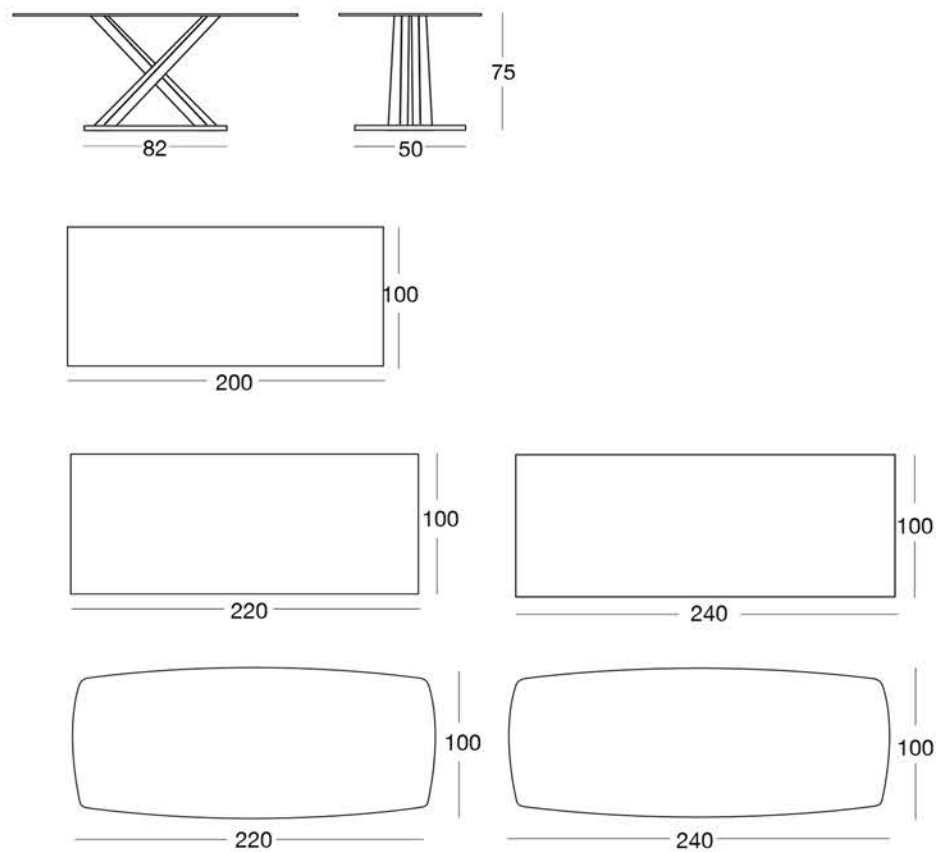



# OBERON

T332 DINING TABLE

BASE: POWDER COATING IN VARIOUS COLOURS

TOP: CERAMIC IN VARIOUS COLORS LAMINATED WITH GLASS

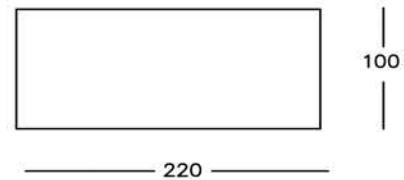
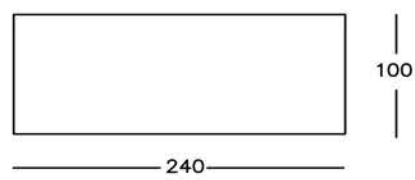
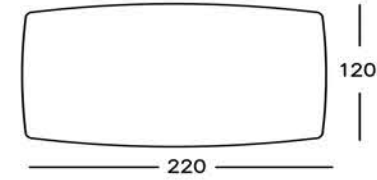
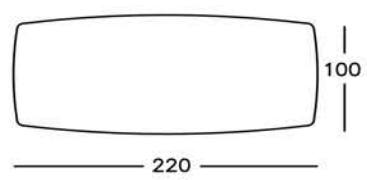
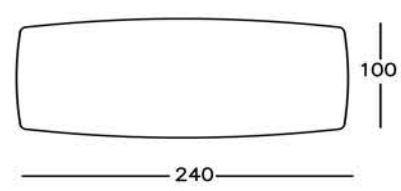
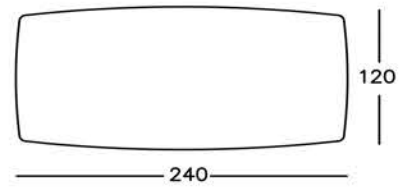
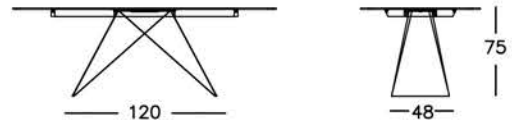



# TRITONE

T323 DINING TABLE

BASE: POWDER COATING IN VARIOUS COLOURS

TOP: CLEAR GLASS OR CERAMIC IN VARIOUS COLORS LAMINATED WITH GLASS

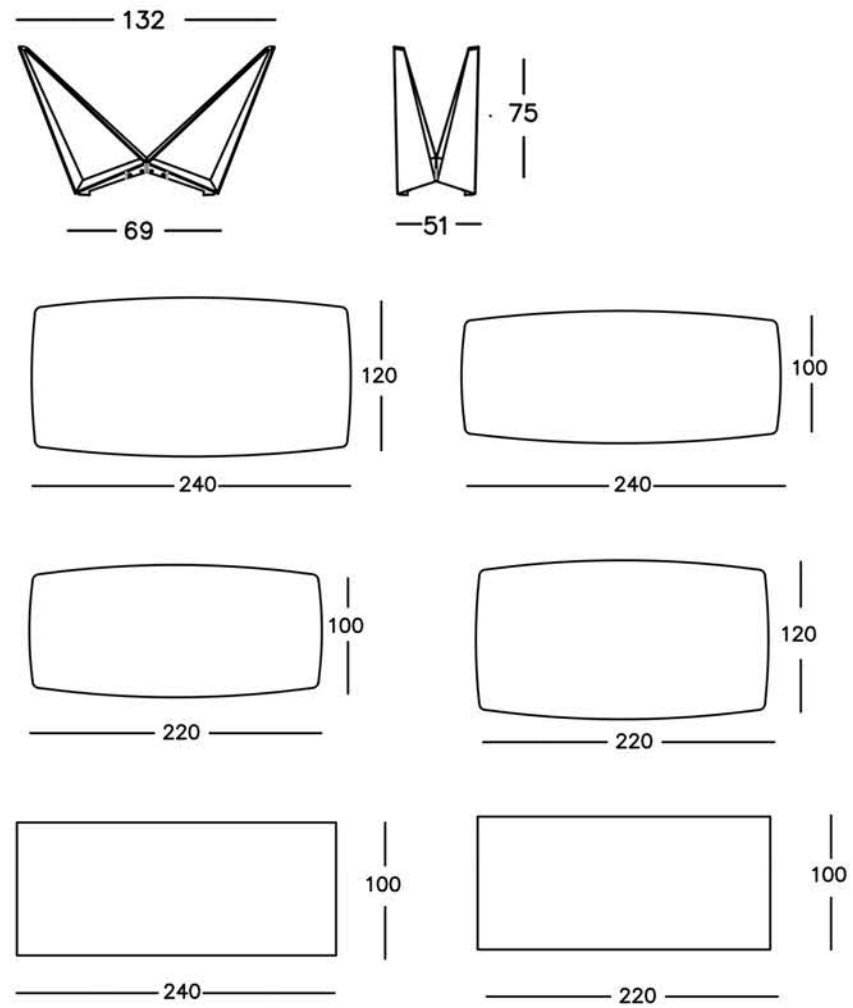



# Oxo F

DESIGN Y. HATANO

T310 DINING TABLE

BASE PLATE: STAINLESS STEEL  
SUPPORT: POWDER COAT, WOOD VENEER  
OR STAINLESS STEEL  
GLASS TOP: CLEAR OR PAINTED MATTE  
CERAMIC TOP: CALA (90CM) OR MATTE (100CM)

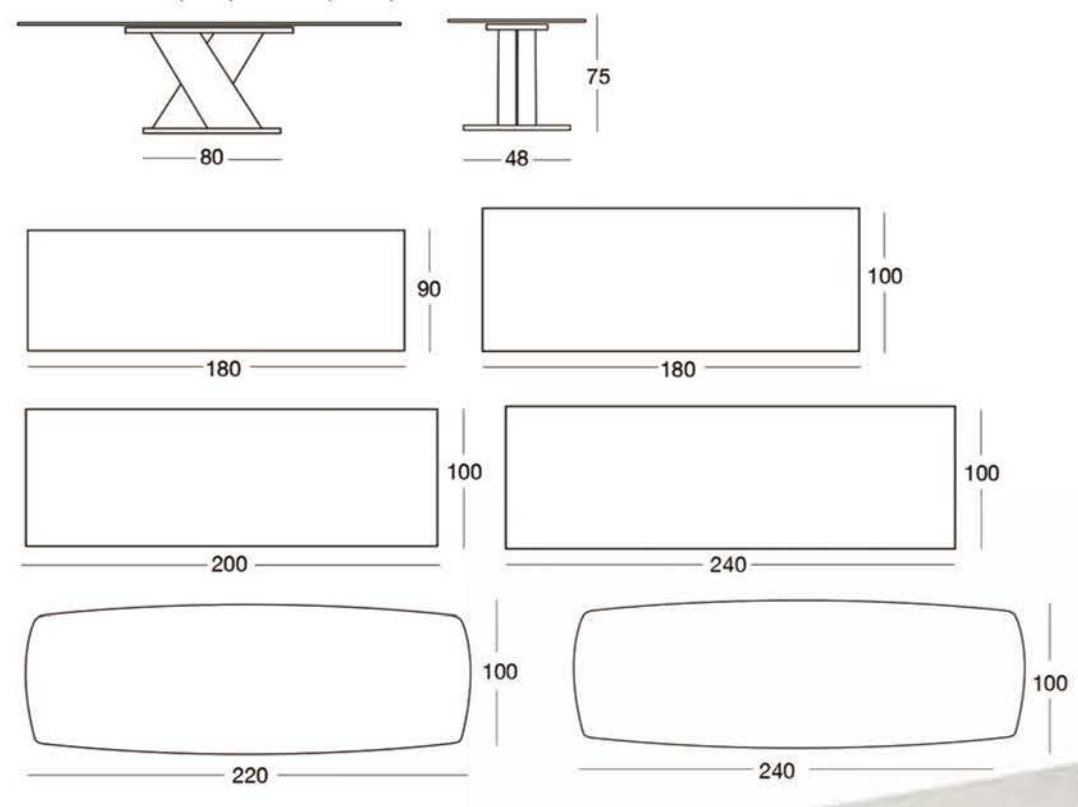



# GIOVENEW

T347 DINING TABLE

BASE: POWDER COATING IN VARIOUS COLOURS

TOP: CERAMIC IN VARIOUS COLORS LAMINATED WITH GLASS

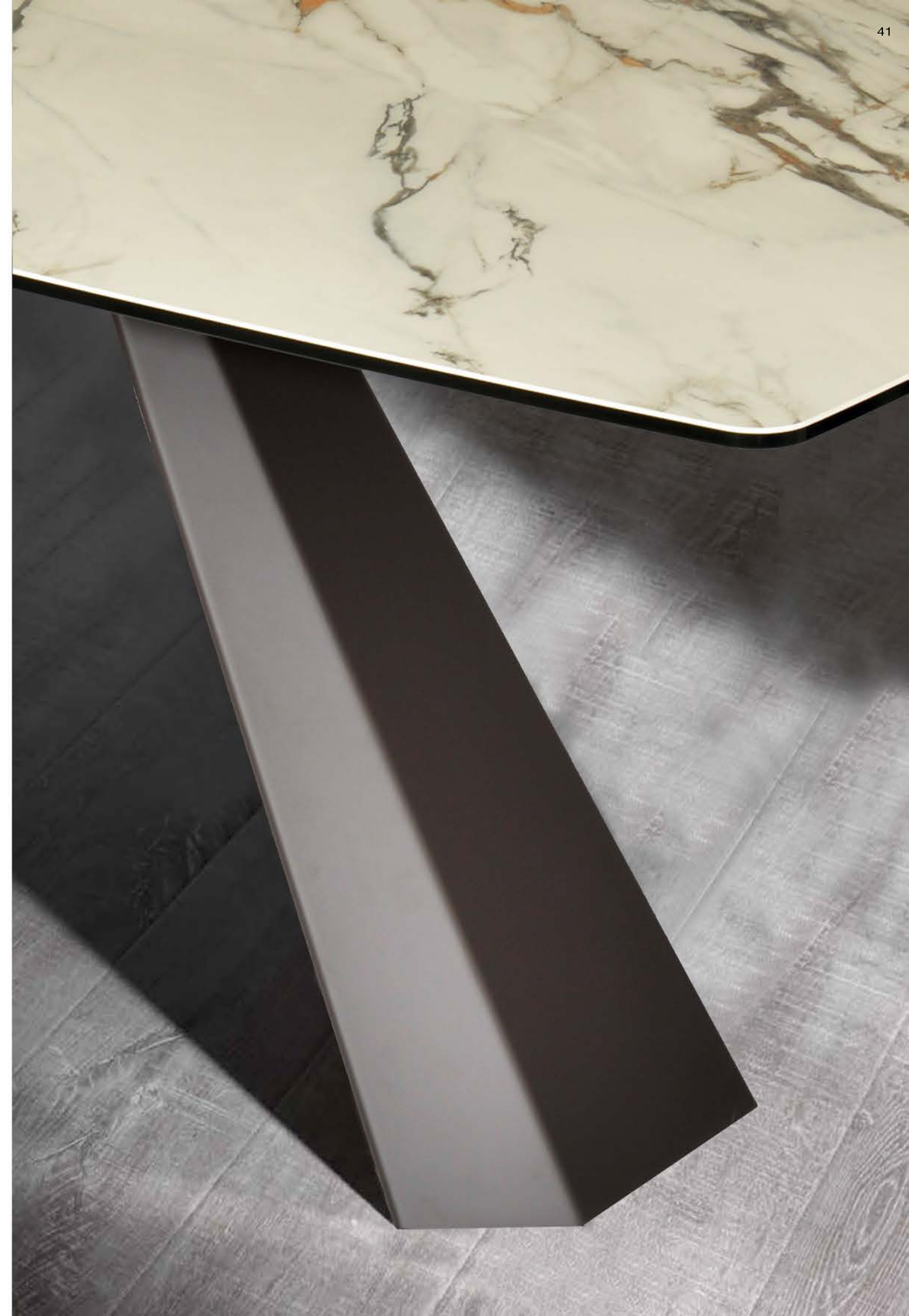
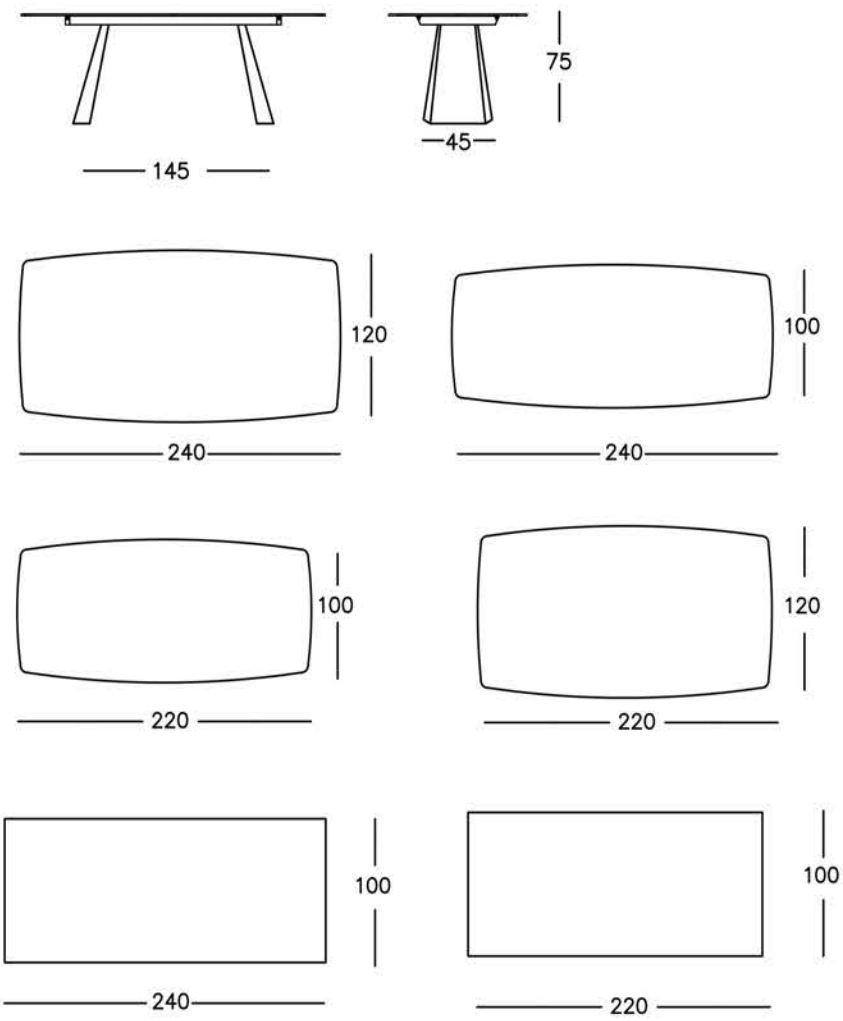





# Giove

DESIGN ITALSTUDIO LAB



# Giove

DESIGN ITALSTUDIO LAB

T292 FIXED DINING TABLE

LEGS: POWDER COAT, SATIN NICKEL

OR MIRROR POLISH STAINLESS STEEL

GLASS TOP: PAINTED MATTE

CERAMIC TOP: MATTE

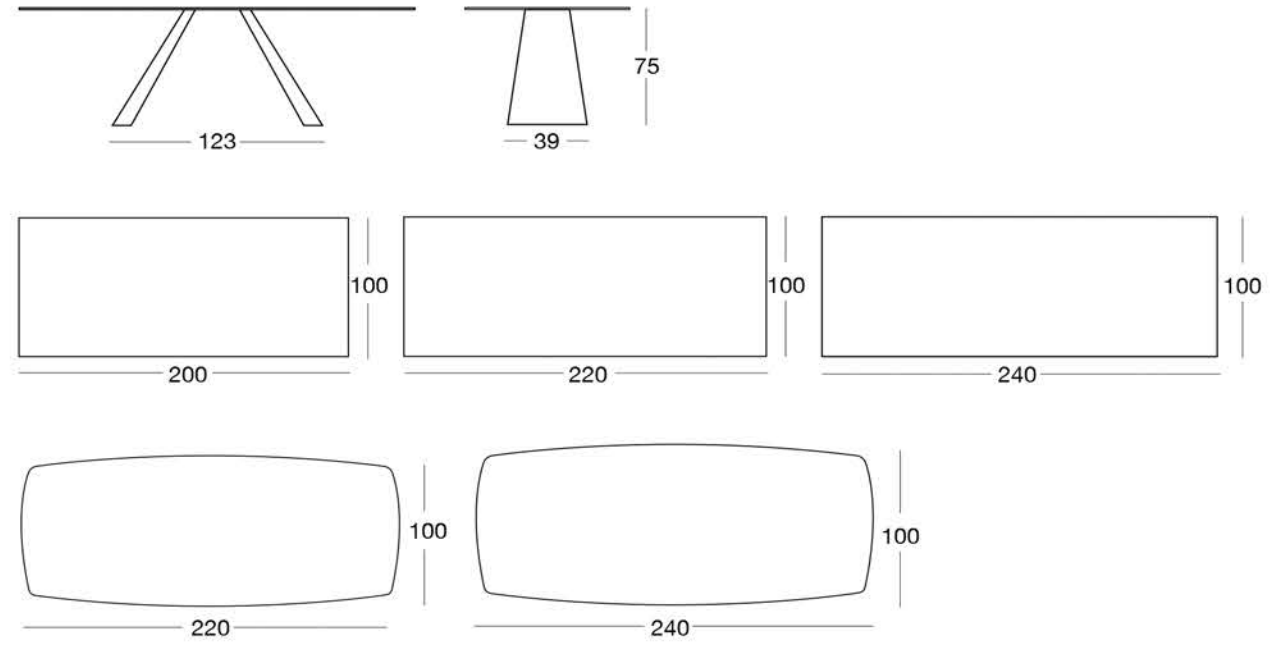





# DOLMEN

T325 DINING TABLE - TOP IN RECTANGLE OR SAGON  
ALUM. LEGS: POWDER COATING IN VARIOUS COLOURS  
TOP: CERAMIC IN VARIOUS COLORS LAMINATED WITH GLASS

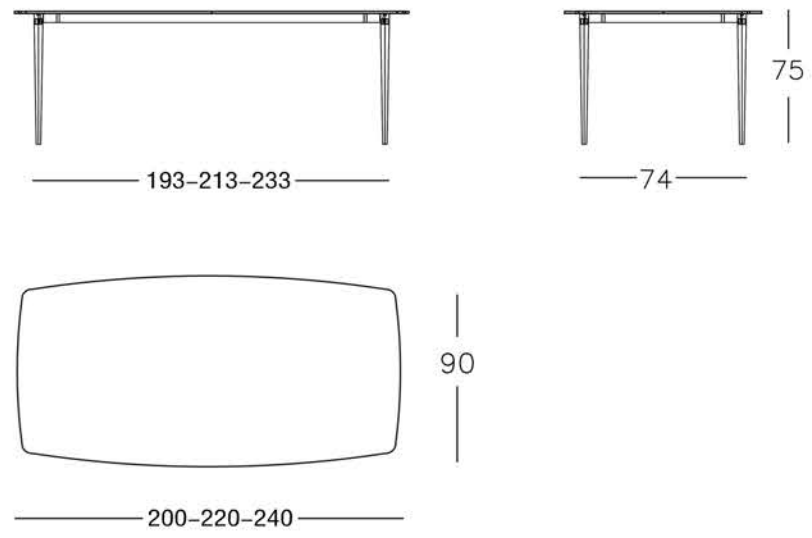



**EXTENSION**



**Tables**



# TANGO

T346 EXTENSION TABLE

BASE: POWDER COATING IN VARIOUS COLOURS

MECHANISM: ALUMINUM BAR IN POWDER COATING IN VARIOUS COLOURS

TOP: CERAMIC IN VARIOUS COLORS LAMINATED WITH GLASS

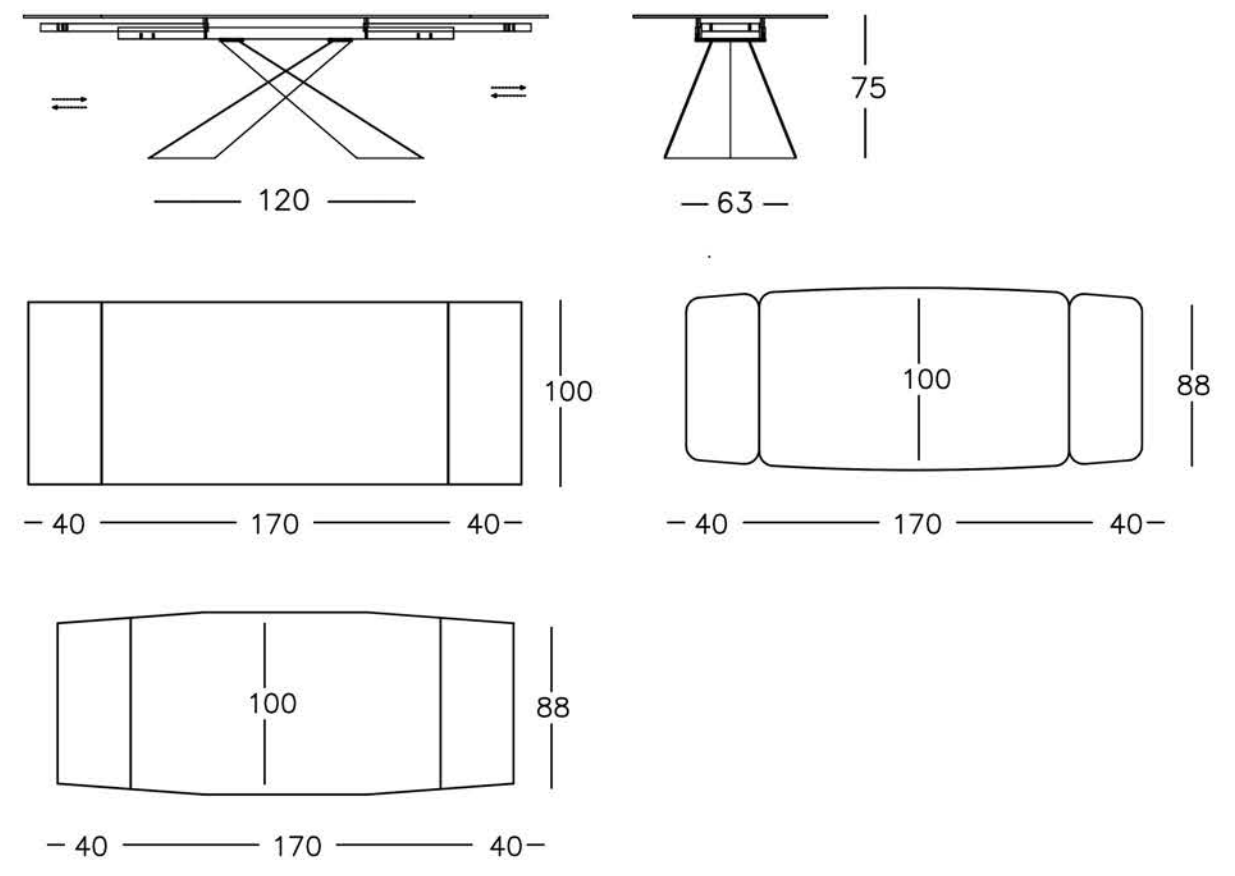

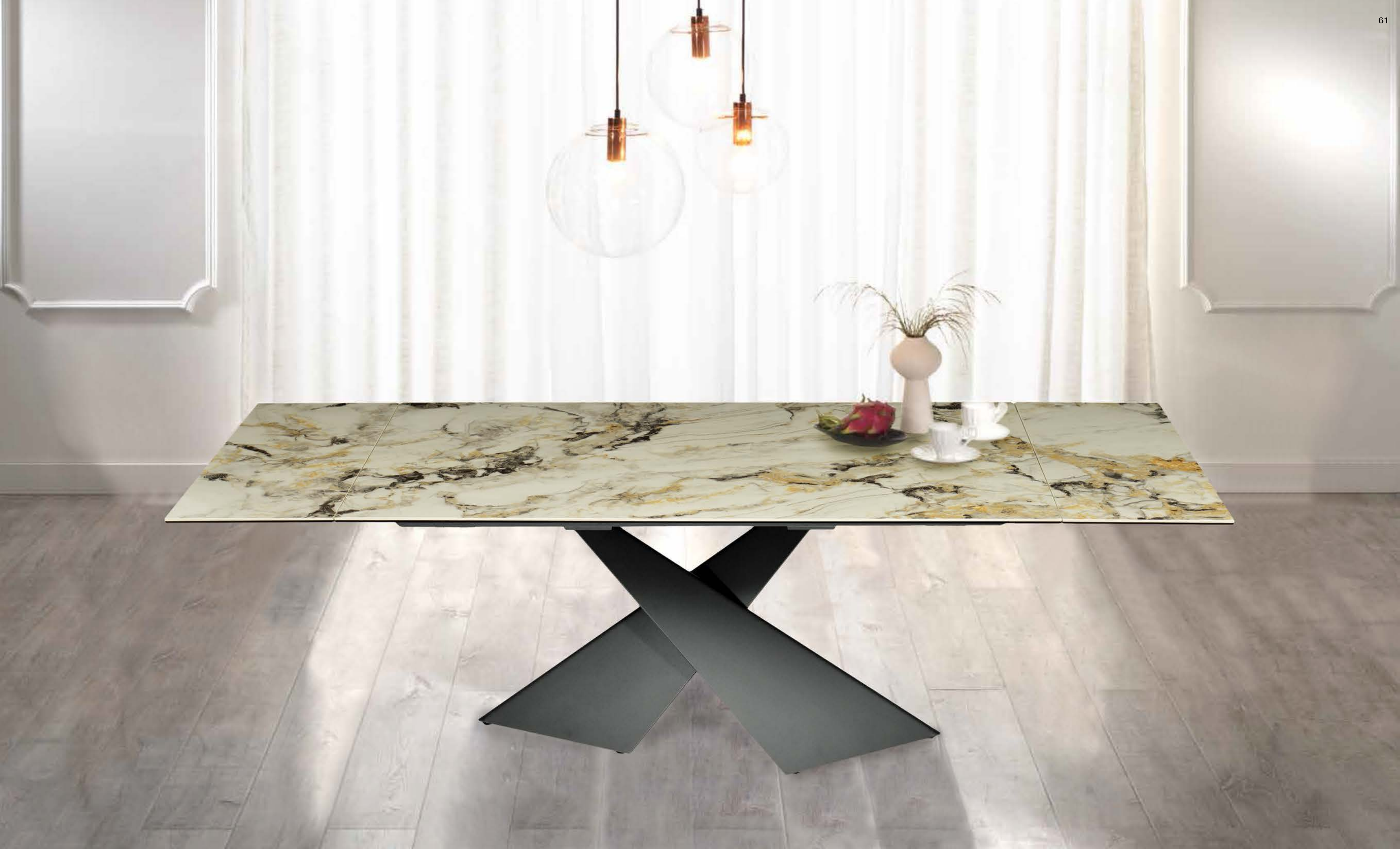

# OBERON

T340 EXTENSION TABLE

BASE: POWDER COATING IN VARIOUS COLOURS

MECHANISM: ALUMINUM BAR IN POWDER COATING IN VARIOUS COLOURS

TOP: CERAMIC IN VARIOUS COLORS LAMINATED WITH GLASS

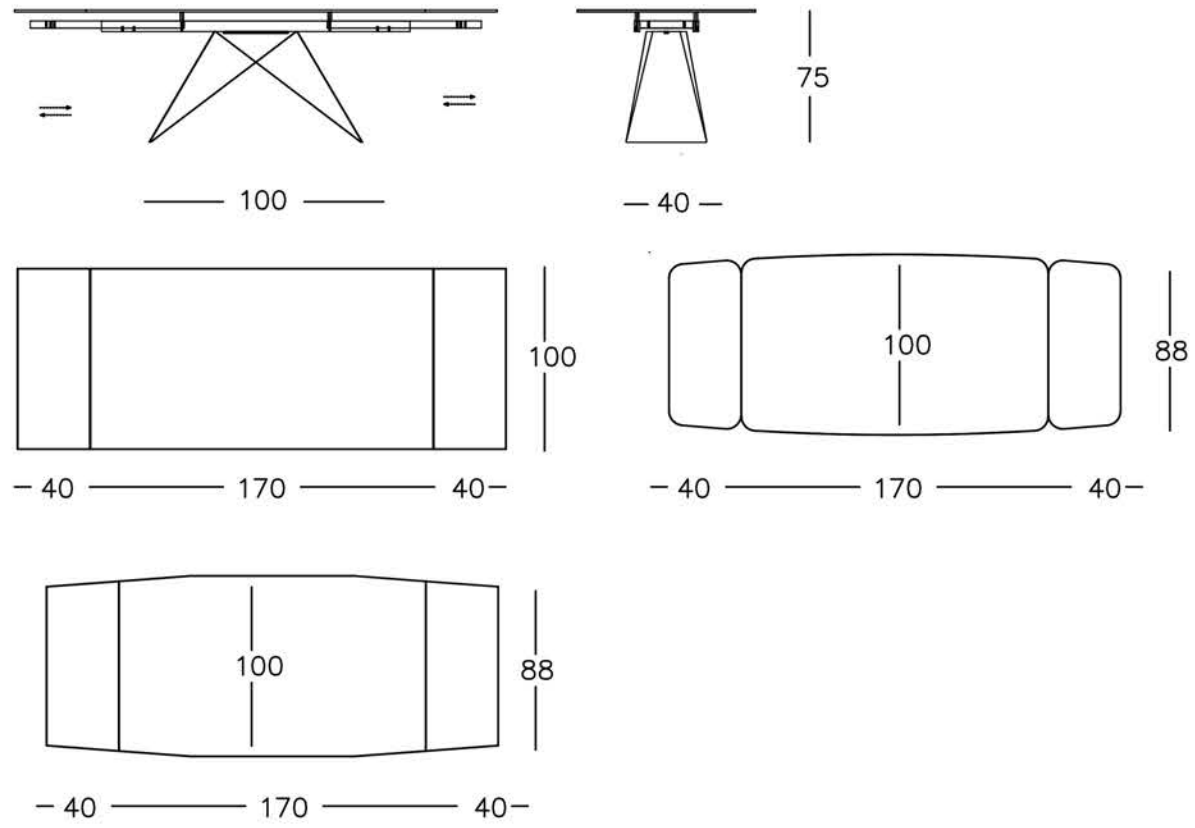



# OBERON

T340 EXTENSION TABLE — RECTANGULAR TOP

T340-0V EXTENSION TABLE — OVAL TOP

BASE: POWDER COATING IN VARIOUS COLOURS

MECHANISM: ALUMINUM BAR IN MIRROR POLISHED OR POWDER COATING IN VARIOUS COLOURS

TOP: CLEAR GLASS OR CERAMIC IN VARIOUS COLORS LAMINATED WITH GLASS

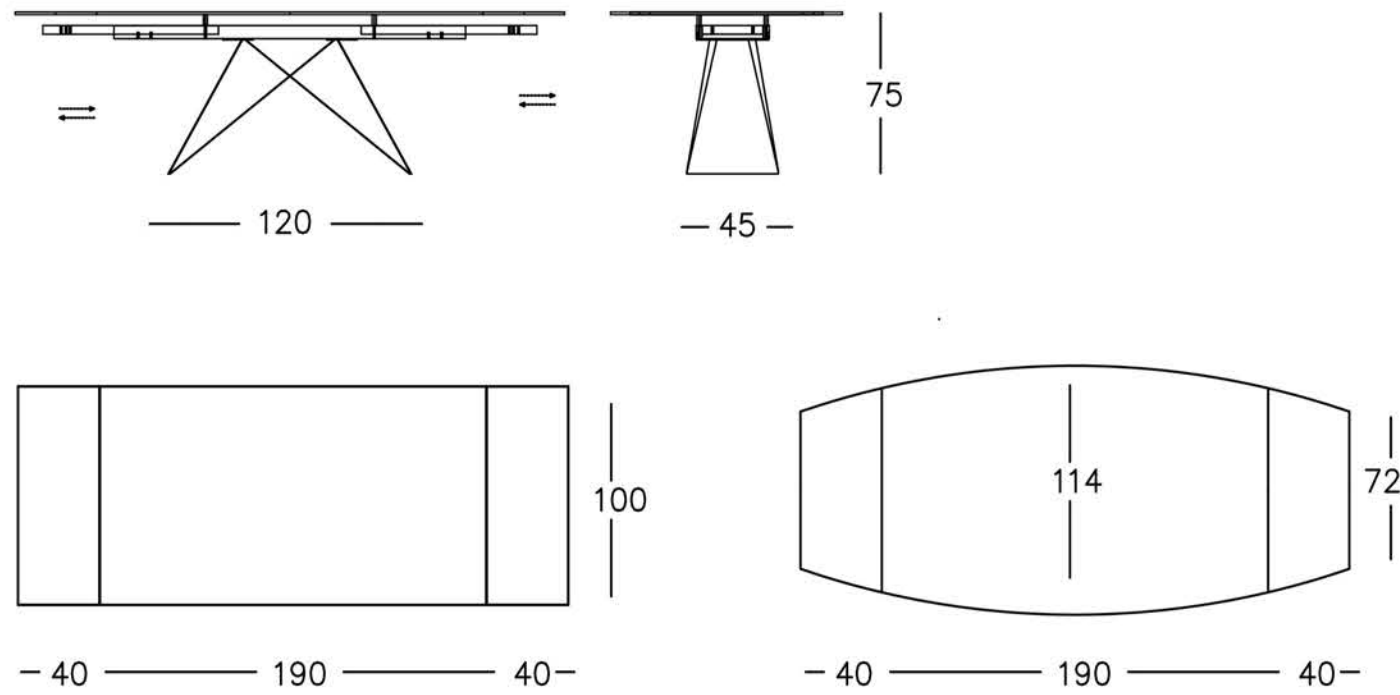





# Mercurio

DESIGN NEDUMO DESIGN



# Mercurio

DESIGN Y. HATANO

T297-OV EXTENSION DINING TABLE - OVAL TOP

T297-R EXTENSION DINING TABLE - RECTANGULAR TOP

BASE PLATE: STAINLESS STEEL

SUPPORT: WOOD VENEER

MECHANISM: ALUMINUM BAR

GLASS TOP: CLEAR OR PAINTED MATTE

CERAMIC TOP: MATTE

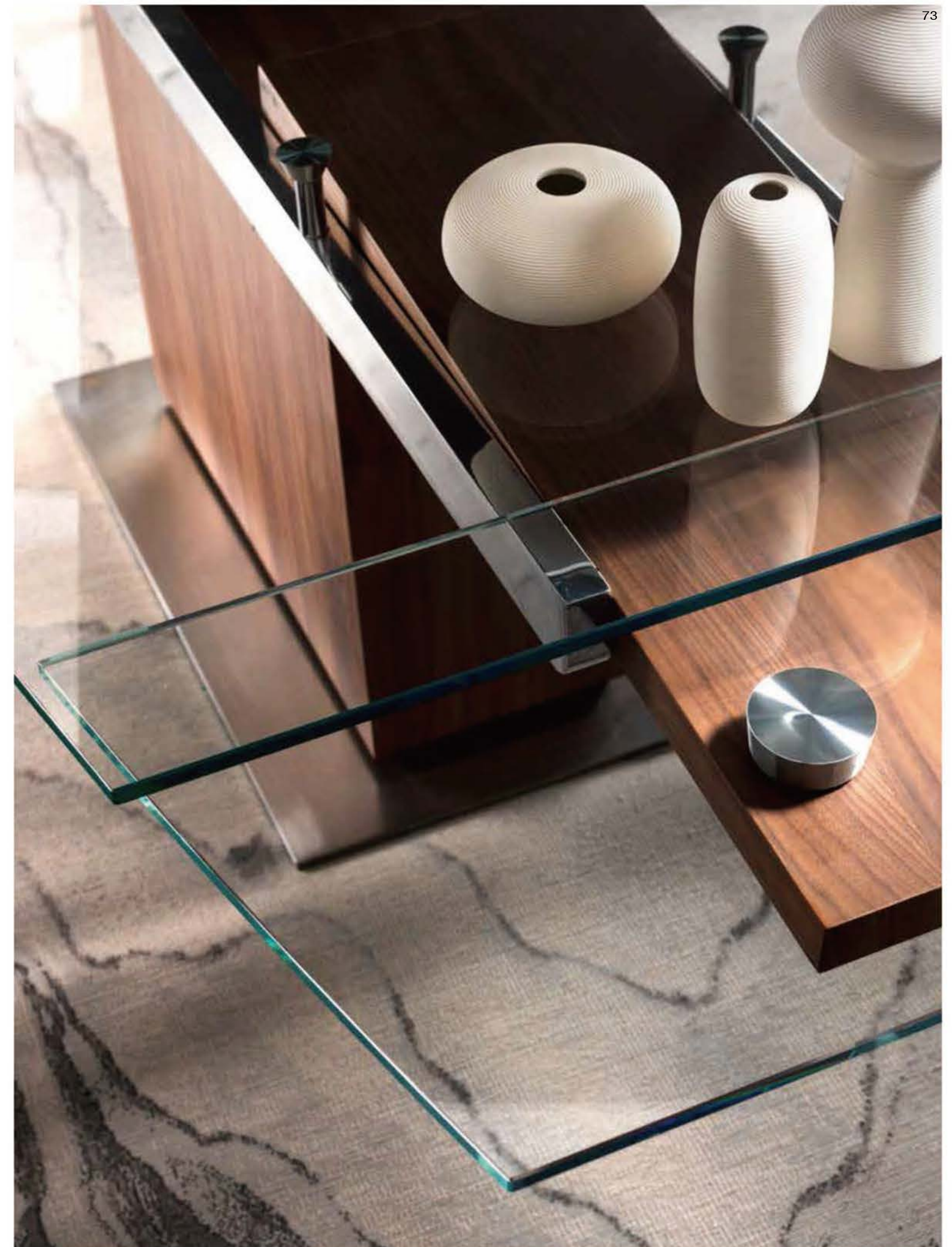
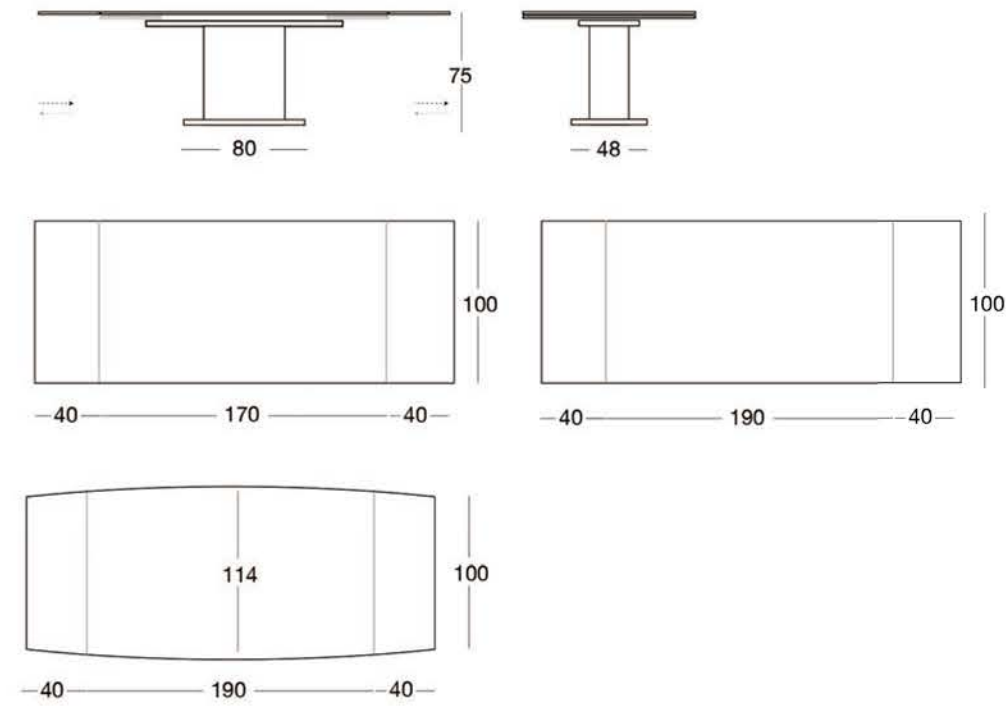



# Oxo

DESIGN Y. HATANO

T307 EXTENSION DINING TABLE - WOOD SUPPORT  
T307/S EXTENSION DINING TABLE - METAL SUPPORT

BASE PLATE: STAINLESS STEEL  
SUPPORT: POWDER COAT, WOOD VENEER  
OR STAINLESS STEEL

GLASS TOP: CLEAR OR PAINTED MATTE  
CERAMIC TOP: MATTE  
MECHANISM: ALUMINUM BAR

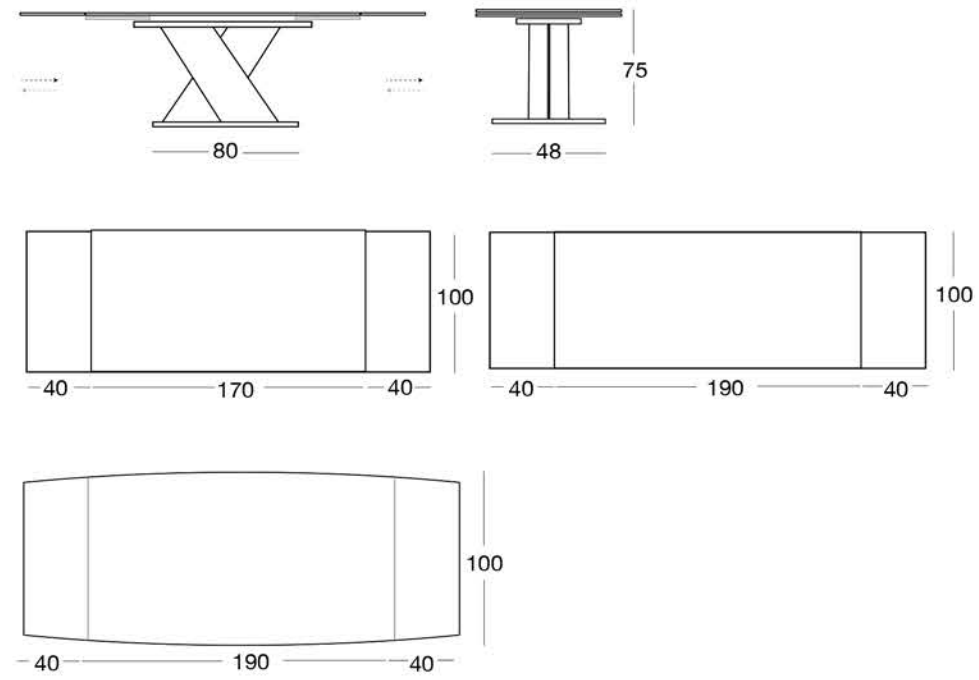



# Uranio

DESIGN ITALSTUDIO LAB

T285 EXTENSION DINING TABLE

LEGS: HIGH GLOSS OR WOOD VENEER

MECHANISM: ALUMINUM BAR

GLASS TOP: CLEAR OR PAINTED MATTE

CERAMIC: MATTE

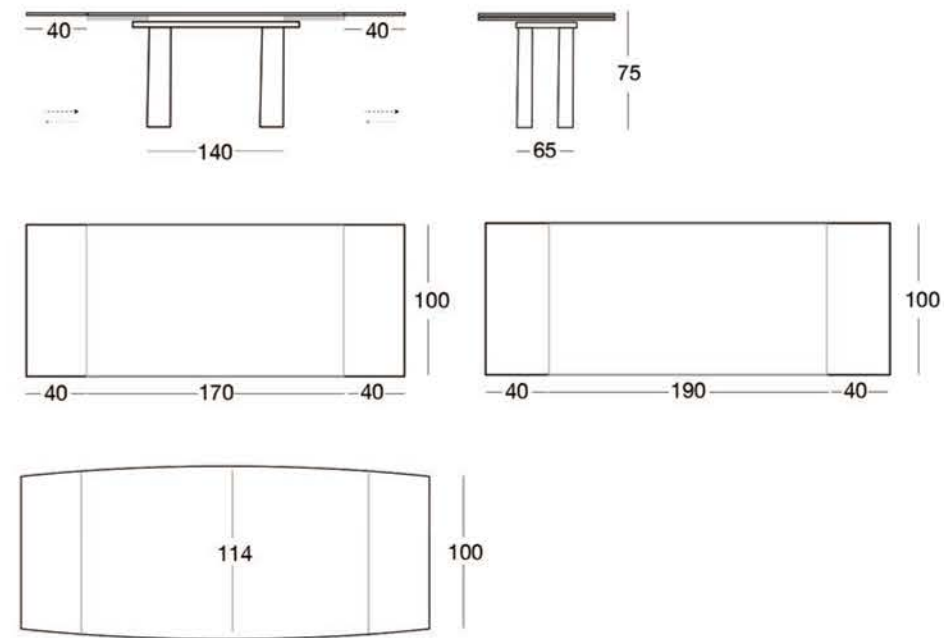





# DEDALO

T352 EXTENSION TABLE

BASE: POWDER COATING IN VARIOUS COLOURS

MECHANISM: PAINTED

TOP: CERAMIC IN VARIOUS COLORS LAMINATED WITH GLASS OR CERAMIC WITH 11MM THICKNESS WITHOUT LAMINATED GLASS MAX 90CM WIDTH

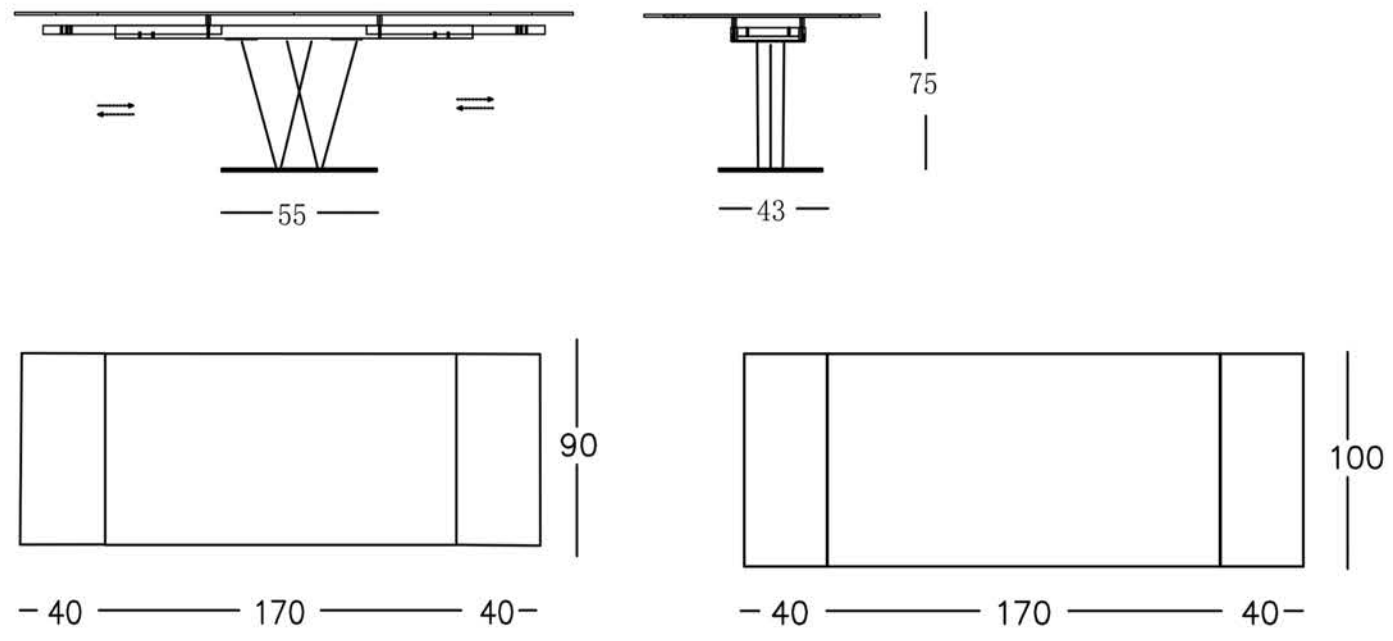



# GIOVIN

T350 EXTENSION TABLE

BASE: POWDER COATING IN VARIOUS COLOURS

MECHANISM: PAINTED

TOP: CERAMIC IN VARIOUS COLORS LAMINATED WITH GLASS OR CERAMIC  
WITH 11MM THICKNESS WITHOUT LAMINATED GLASS MAX 90CM WIDTH

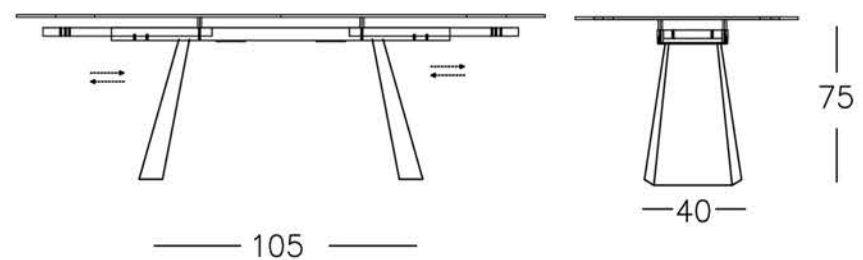



# Tito

DESIGN NEDUMO DESIGN

T315 EXTENSION DINING TABLE

LEGS: POWDER COATING STEEL TUBE

MECHANISM: BLACK PAINTED

CERAMIC TOP: CARRARA

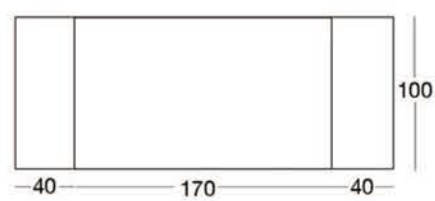

THE BLACK PARTS ARE AVAILABLE JUST IN BLACK.





# GEMMA

T348 EXTENSION TABLE

LEGS: POWDER COATING IN VARIOUS COLOURS

MECHANISM: ALUMINUM BAR IN POWDER COATING IN VARIOUS COLOURS

TOP: CERAMIC IN VARIOUS COLORS LAMINATED WITH GLASS

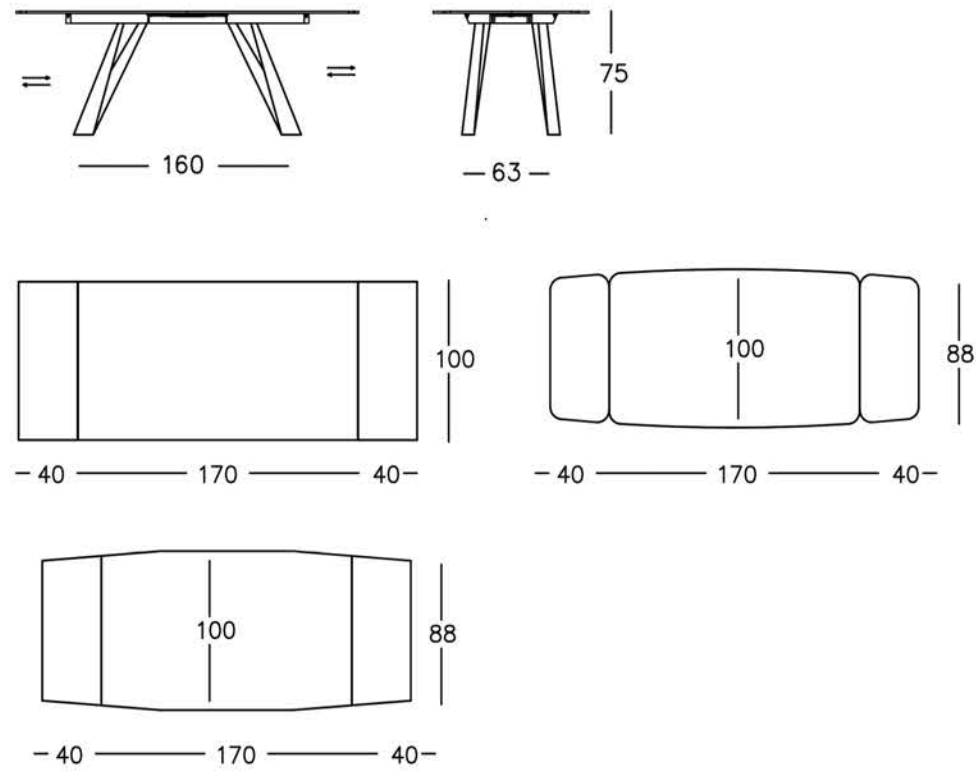





# Titano

DESIGN NEDUMO DESIGN



# Titano

DESIGN NEDUMO DESIGN

T294 EXTENSION DINING TABLE

LEGS: POWDER COAT, SATIN NICKEL

OR MIRROR POLISH STAINLESS STEEL.

GLASS TOP: CLEAR, SMOKE OR PAINTED MATTE

CERAMIC TOP: CALA (90CM) OR MATTE

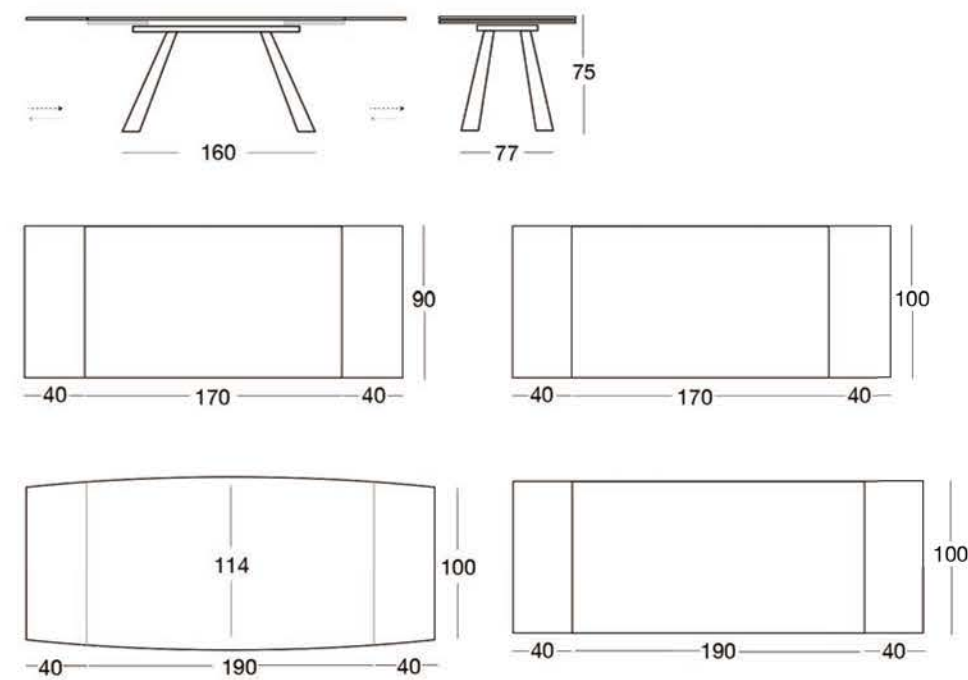



# GEMELLO

T217 ROUND DINING TABLE

BASE: POWDER COATING IN VARIOUS COLOURS

TOP: CERAMIC IN VARIOUS COLORS LAMINATED WITH GLASS

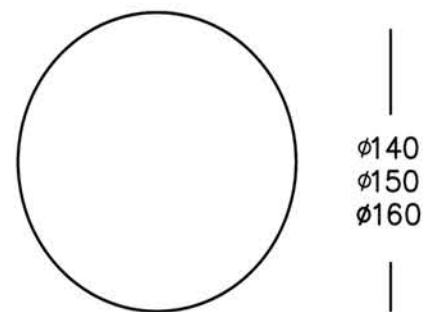
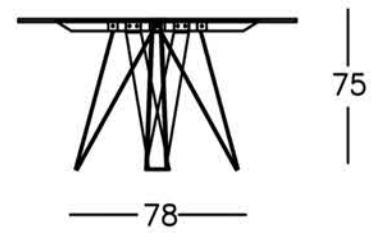



# CASSIO

T219 ROUND DINING TABLE

BASE: POWDER COATING IN VARIOUS COLOURS

TOP: CERAMIC IN VARIOUS COLORS LAMINATED WITH GLASS

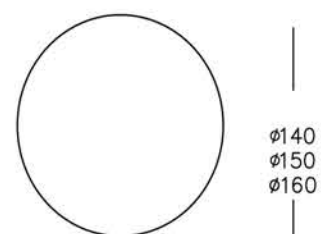
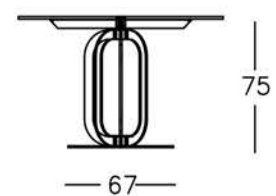



# Rimini

DESIGN ITALSTUDIO LAB



# Rimini

DESIGN ITALSTUDIO LAB

T120-1 ROUND DINING TABLE WITH LAZY SUSAN

BASE PLATE: BRUSHED STAINLESS STEEL  
COLUMN: ECOCUOIO LEATHER  
SUPPORT: POWDER COAT, CHROME OR SATIN NICKEL  
GLASS TOP: CLEAR OR SMOKE

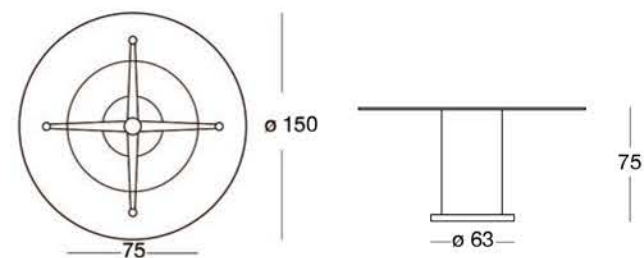

# Trident

DESIGN NEDUMO DESIGN

T212 ROUND DINING TABLE

BASE/SUPPORT: POWDER COAT OR MIRROR POLISH  
STAINLESS STEEL  
GLASS TOP: CLEAR, SMOKE  
OR LAMINATED "CRACKED"

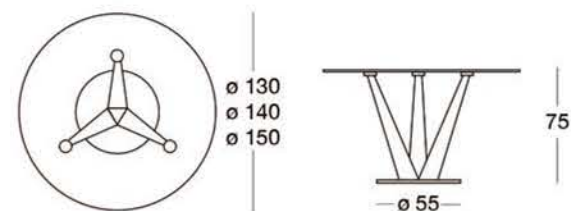





# Prisma

---

DESIGN ITALSTUDIO LAB

# Prisma

DESIGN ITALSTUDIO LAB

DT1137 ROUND TABLE

FRAME/PLATE: POWDER COAT

OR BRUSHED STAINLESS STEEL

GLASS TOP: CLEAR OR PAINTED MATTE

CERAMIC: MATTE (ø100)

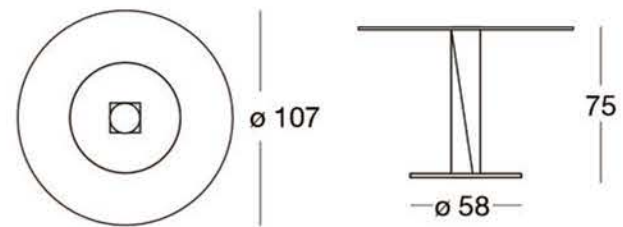

# DOLMEN

T349 ROUND DINING TABLE

ALUM. LEGS: POWDER COATING IN VARIOUS COLOURS

TOP: CERAMIC IN VARIOUS COLORS LAMINATED WITH GLASS

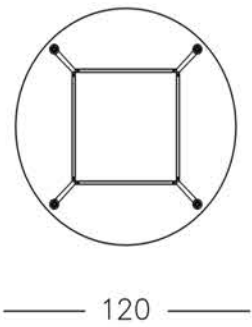
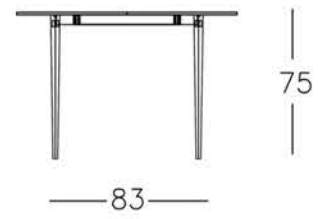

# Home Office

---

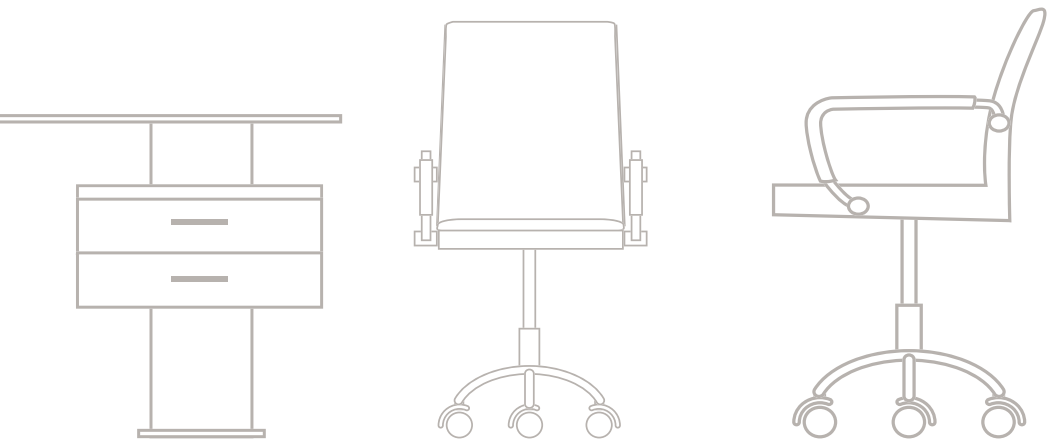

# Traglass

DESIGN NEDUMO DESIGN

T687 BENT GLASS DESK

COLUMN: CHROME OR SATIN NICKEL  
DRAWER: HIGH GLOSS, WOOD VENEER OR ECOCUOIO LEATHER  
GLASS TOP: 15MM CLEAR OR 12MM SMOKE

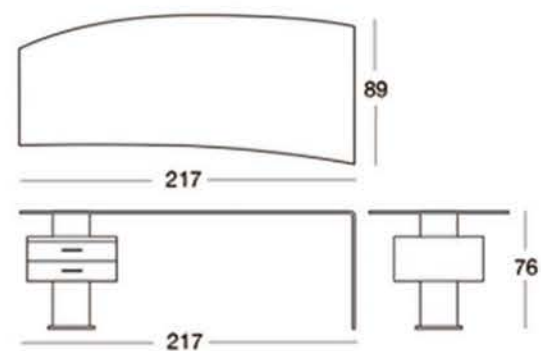



# Trapeze

DESIGN ITALSTUDIO LAB

T688GL Desk

COLUMN: ECOCUOIO LEATHER, CHROME OR SATIN NICKEL  
DRAWER AND SUPPORT: HIGH GLOSS, WOOD VENEER OR  
ECOCUOIO LEATHER

15MM GLASS: CLEAR OR PAINTED MATTE

CERAMIC: MATTE

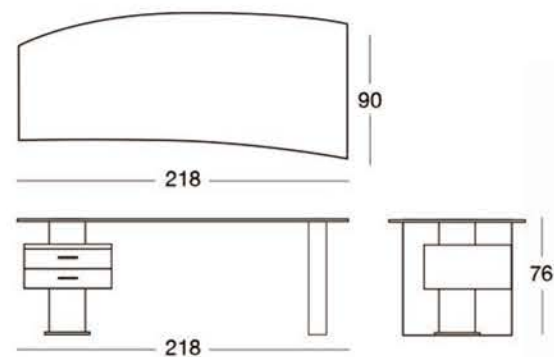

# Trapeze



# Katie

DESIGN ITALSTUDIO LAB

T170 DESK

COLUMN: ECOCUOIO LEATHER, CHROME OR SATIN NICKEL  
 KIDNEY PEDESTAL: ECOCUOIO LEATHER  
 DRAWER: ECOCUOIO LEATHER, HIGH GLOSS OR WOOD VENEER  
 15MM GLASS TOP: CLEAR, SMOKE OR PAINTED MATTE

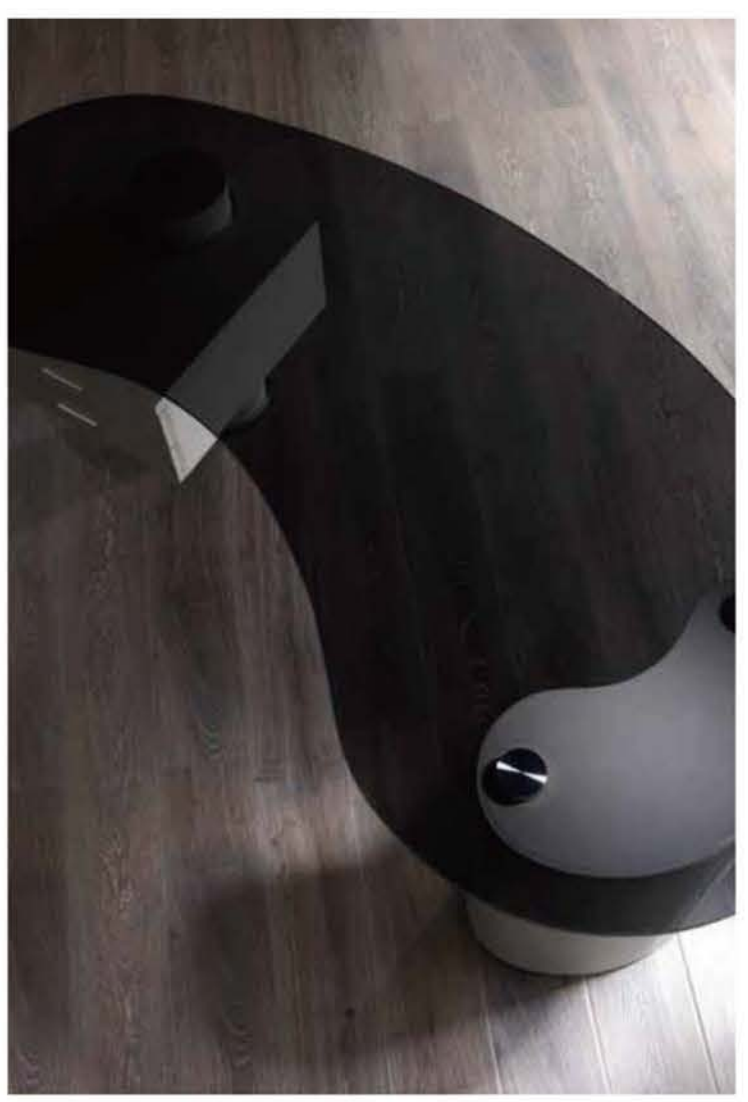
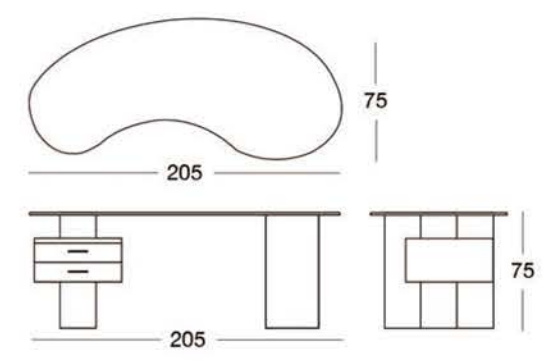

# ROSA

T694 DESK

FRAME: POWDER COATING IN BLACK

TOP: WOODEN IN BLACK MATTE PAINTED OR BLACK HIGH GLOSS

DRAWER: WOODEN IN WALNUT VENEER OR EBONY VENEER

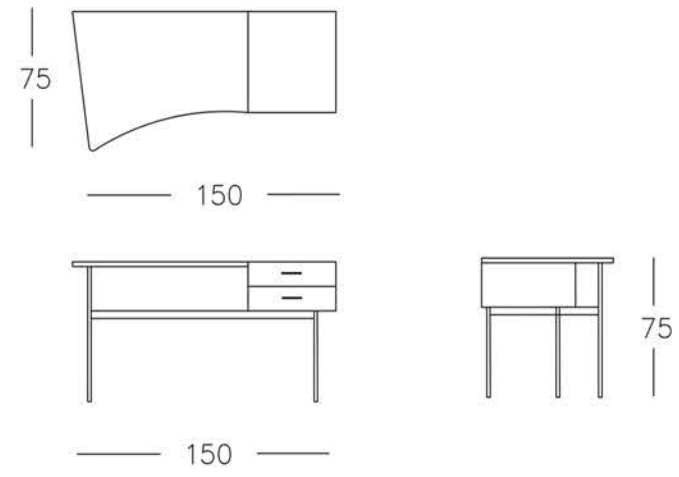



## Soft HO

DESIGN NEDUMO DESIGN

**C505HO-AF** HEIGHT ADJUSTABLE OFFICE CHAIR

5 SPOKE STEEL BASE/SUPPORT: POWDER COAT, CHROME  
OR STAIN NICKEL

UPHOLSTERY/ARM PADS: GENUINE LEATHER, MICROPELLE,  
ECOPELLE OR FABRIC

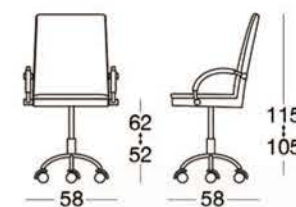

# Venince HO

DESIGN ITALSTUDIO LAB

C103HO-AF-I HEIGHT ADJUSTABLE

C103HO-AF-G-I HEIGHT ADJUSTABLE (BIG SIZE)

5 SPOKE STEEL BASE/SUPPORT: POWDER COAT, CHROME OR STAIN NICKEL

UPHOLSTERY/ARM PADS: ECOCUOIO LEATHER (ALSO AVAILABLE IN VERA MODEL)

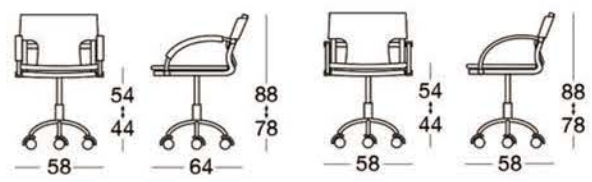

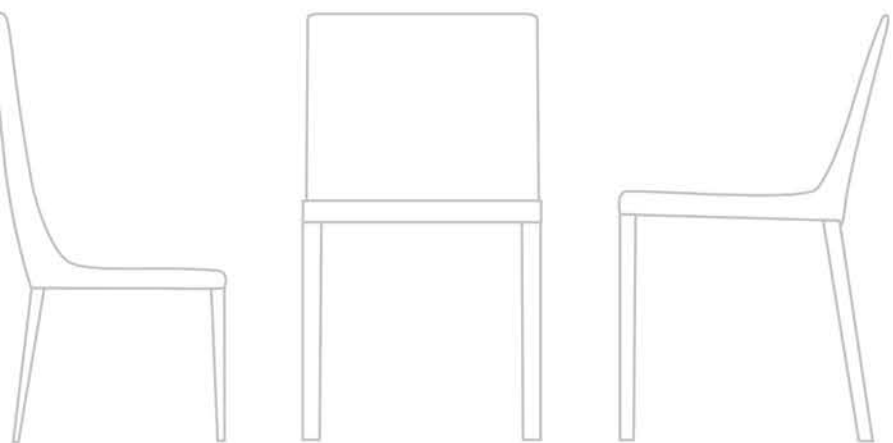

# Chairs

---

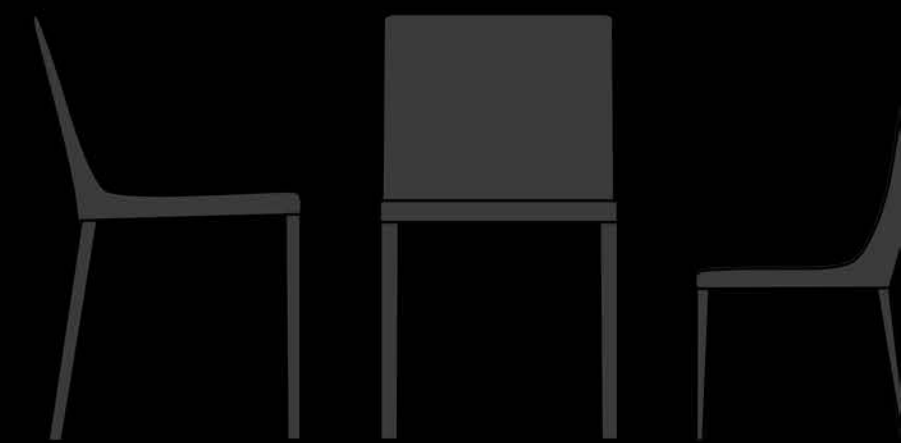

# ANTINA

**G617A CHAIR**  
FRAME: POWDER COATING IN VARIOUS COLOURS  
UPHOLSTERY: ECOPELLE OR GENUINE LEATHER

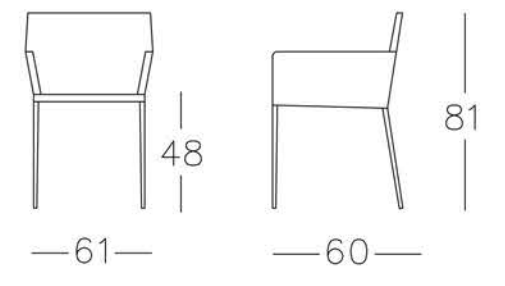



## ANTINA

C617A/T-2 TURNING CHAIR

BASE: POWDER COATING IN VARIOUS COLOURS

UPHOLSTERY: ECOPELLE OR GENUINE LEATHER

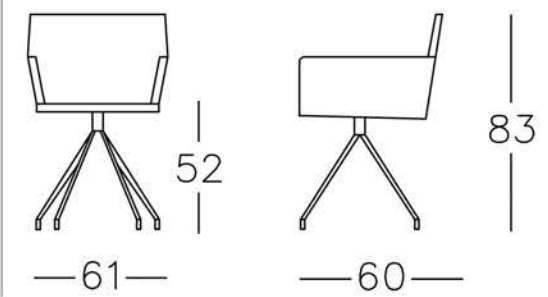

## ANTINA

C617A/T TURNING CHAIR

MECHANISM: AUTOMATIC RETURN

BASE: POWDER COATING IN VARIOUS COLOURS

UPHOLSTERY: ECOPELLE OR GENUINE LEATHER

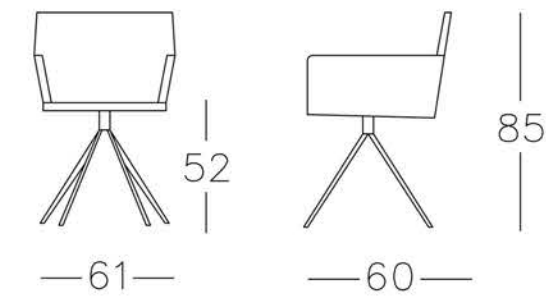

# LOGE

C625 CHAIR

FRAME: CHROME OR POWDER COATING IN VARIOUS COLOURS

UPHOLSTERY: ECOPELLE OR GENUINE LEATHER

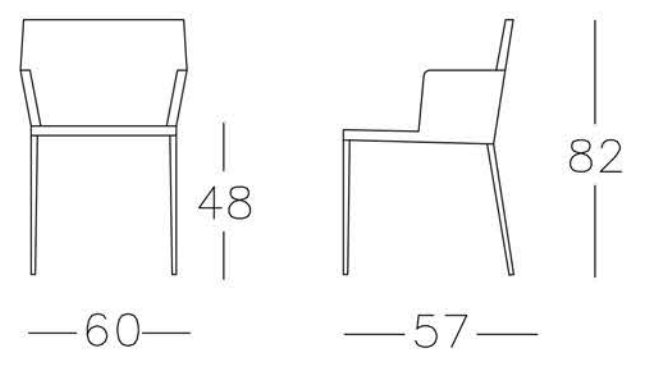



# ALTANA

**G626A CHAIR**

FRAME: POWDER COATING IN VARIOUS COLOURS

UPHOLSTERY: ECOPELLE OR GENUINE LEATHER

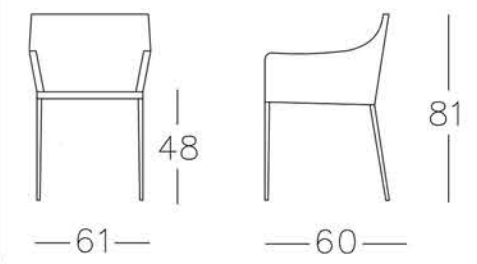

# ALTANA

**G626A/T TURNING CHAIR**

MECHANISM: AUTOMATIC RETURN

BASE: POWDER COATING IN VARIOUS COLOURS

UPHOLSTERY: ECOPELLE OR GENUINE LEATHER

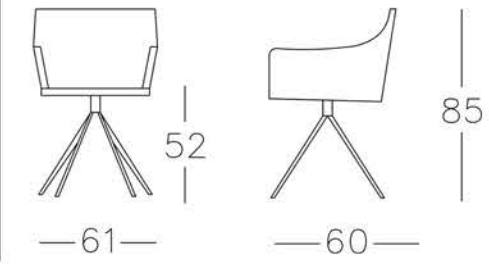



## LORETTA

C623 CHAIR

FRAME: POWDER COATING IN VARIOUS COLOURS

UPHOLSTERY: ECOPELLE OR GENUINE LEATHER

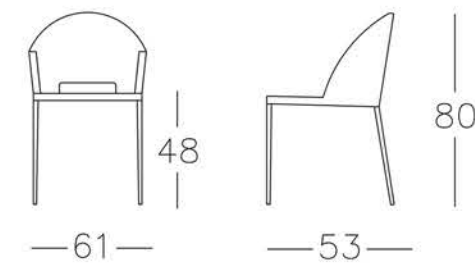



## MARINA

C613/F CHAIR

C613/T TURNING CHAIR (MECHANISM: AUTOMATIC RETURN)

BASE: POWDER COATING IN VARIOUS COLOURS

UPHOLSTERY: ECOPELLE OR GENUINE LEATHER

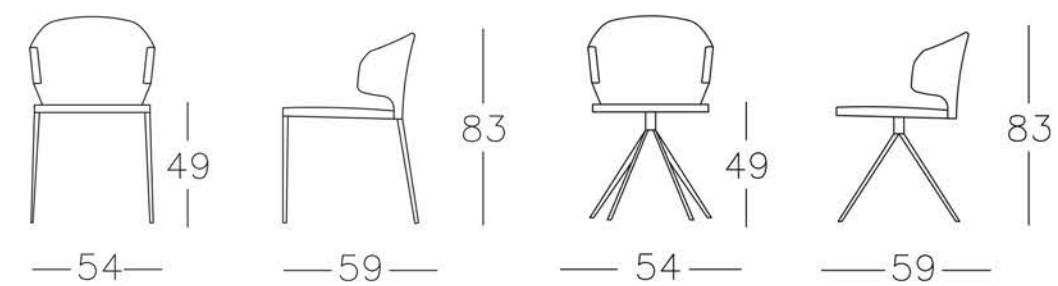



## BOLOGNA

C612/F CHAIR

C612/T TURNING CHAIR (MECHANISM: AUTOMATIC RETURN)

BASE: POWDER COATING IN VARIOUS COLOURS

UPHOLSTERY: ECOPELLE OR GENUINE LEATHER

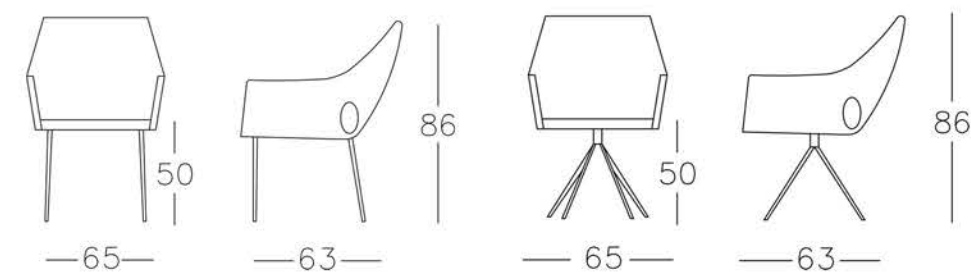





## GENOVA

C611/F CHAIR

BASE: POWDER COATING IN VARIOUS COLOURS

UPHOLSTERY: ECOPELLE OR GENUINE LEATHER

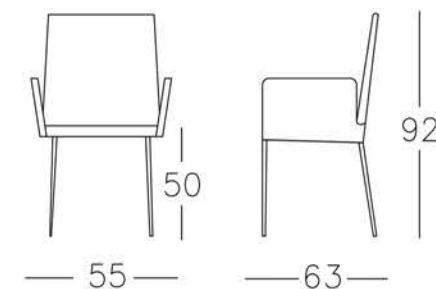

## GENOVA

C611/T TURNING CHAIR

MECHANISM: AUTOMATIC RETURN

BASE: POWDER COATING IN VARIOUS COLOURS

UPHOLSTERY: ECOPELLE OR GENUINE LEATHER

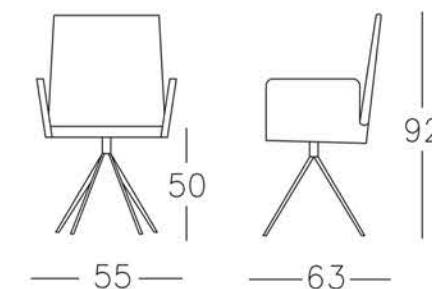



## Anna

DESIGN NEDUMO DESIGN

C531 MOTION CHAIR

FRAME: POWDER COAT, CHROME OR SATIN NICKEL

UPHOLSTERY: ECOPELLE, GENUINE LEATHER, MICROPELLE  
OR FABRIC.

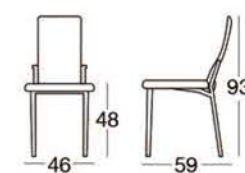

# Anna Soft

DESIGN NEDUMO DESIGN

C548 MOTION CHAIR

FRAME: POWDER COAT, CHROME OR SATIN NICKEL

UPHOLSTERY: ECOPELLE, GENUINE LEATHER, MICROPELLE  
OR FABRIC

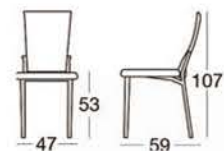





## BARLETTA

C562 MOTION CHAIR

FRAME: POWDER COATING IN VARIOUS COLOURS,  
CHROME OR SATIN NICKEL

UPHOLSTERY: ECOPELLE, MICROPELLE OR GENUINE LEATHER

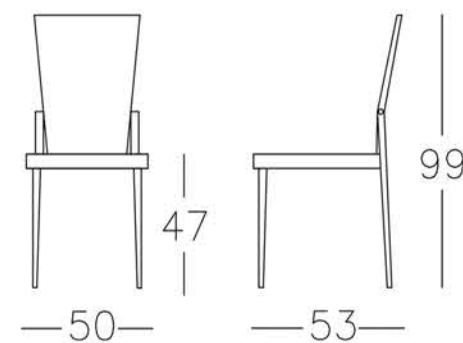



## FOGGIA

C563 MOTION CHAIR

FRAME: POWDER COATING IN VARIOUS COLOURS,  
CHROME OR SATIN NICKEL

UPHOLSTERY: ECOPELLE, MICROPELLE OR GENUINE LEATHER

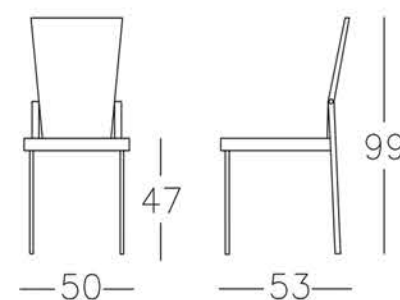

# TRANI

C564 MOTION CHAIR

FRAME: POWDER COATING IN VARIOUS COLOURS,  
CHROME OR SATIN NICKEL

UPHOLSTERY: ECOPELLE, MICROPELLE OR GENUINE LEATHER

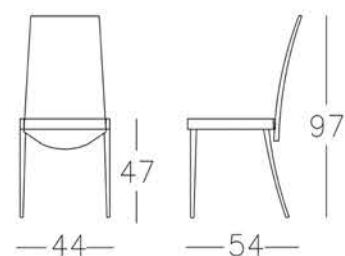



## Maxsoft

DESIGN NEDUMO DESIGN

C498 CHAIR

FRAME: POWDER COATED STEEL

CONIC LEGS: POWDER COAT, SATIN NICKEL OR CHROME.

UPHOLSTERY: GENUINE LEATHER, MICROPELLE, ECOPELLE  
OR FABRIC.

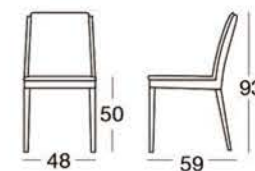

# Maxari

DESIGN NEDUMO DESIGN

C515 CHAIR

FRAME: POWDER COATED STEEL

CONIC LEGS: POWDER COAT, CHROME OR SATIN NICKEL

UPHOLSTERY: GENUINE LEATHER, MICROPELLE, ECOPELLE  
OR FABRIC

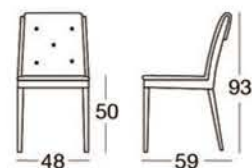



# Monica

DESIGN ISABELLE RIGAL

C534 CHAIR

C534HB HIGH-BACK CHAIR

FRAME: POWDER COATED STEEL

CONIC LEGS: POWDER COAT, CHROME OR SATIN NICKEL

UPHOLSTERY: GENUINE LEATHER, MICROPELLE, ECOPELLE  
OR FABRIC

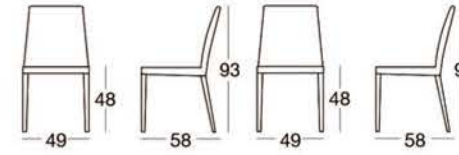

# Alessia

DESIGN ISABELLE RIGAL

C451 CHAIR

FRAME: POWDER COATED STEEL  
BASE: POWDER COAT, CHROME OR SATIN NICKEL  
UPHOLSTERY: ECOPELLE, FABRIC,  
MICROPELLE OR GENUINE LEATHER

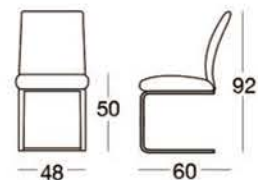

# Alex

DESIGN ISABELLE RIGAL

C475 CHAIR

FRAME: POWDER COATED STEEL  
BASE: POWDER COAT, CHROME OR SATIN NICKEL  
UPHOLSTERY: ECOPELLE, FABRIC,  
MICROPELLE OR GENUINE LEATHER

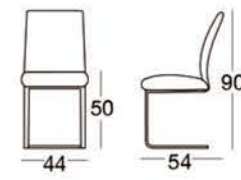



## Bonaria

DESIGN ITALSTUDIO LAB

C484 CHAIR

FRAME: POWDER COATED STEEL  
 SUPPORT: INJECTION MOLDED FOAM  
 UPHOLSTERY: ECOPELLE, FABRIC,  
 MICROPELLE OR GENUINE LEATHER

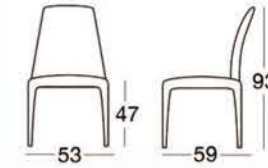

## Bonaccia

DESIGN ITALSTUDIO LAB

C456 CHAIR

FRAME: POWDER COATED STEEL  
 SUPPORT: INJECTION MOLDED FOAM  
 UPHOLSTERY: ECOPELLE, FABRIC,  
 MICROPELLE OR GENUINE LEATHER

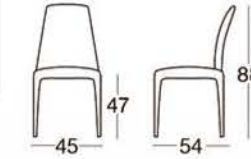



## Sina

DESIGN ITALSTUDIO LAB

C494 CHAIR

FRAME: POWDER COATED STEEL

STRUCTURE: INJECTION MOLDED FOAM

UPHOLSTERY: GENUINE LEATHER, MICROPELLE,

ECOPELLE OR FABRIC

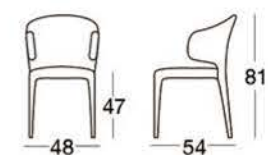



## Mara

DESIGN ISABELLE RIGAL

**C529** HIGH BACK CHAIR

FRAME: POWDER COAT STEEL

CONIC LEGS: POWDER COAT, CHROME OR SATIN NICKEL

UPHOLSTERY: ECOPELLE, FABRIC, MICROPELLE OR GENUINE LEATHER.

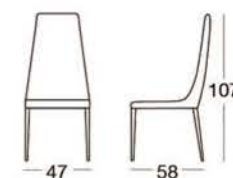



## Altea

DESIGN GIUSY MASTRO

C469S CHAIR

FRAME: POWDER COATED STEEL

CONIC LEGS: POWDER COAT, CHROME OR SATIN NICKEL

UPHOLSTERY: GENUINE LEATHER, MICROPELLE, ECOPELLE  
OR FABRIC

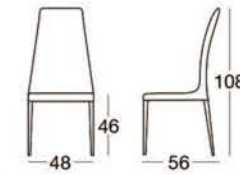



# Emma

DESIGN ITALSTUDIO LAB

C420 CHAIR  
C420HB HIGH-BACK CHAIR

FRAME: POWDER COATED STEEL  
LEGS: LEATHER WRAPPED  
UPHOLSTERY: ECOCUOIO LEATHER.

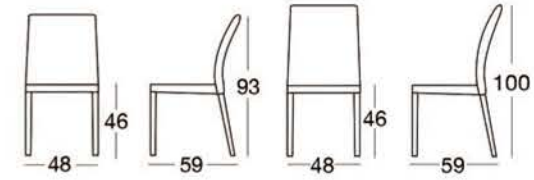

# Rebe

DESIGN ITALSTUDIO LAB

C489 CHAIR

FRAME: POWDER COATED STEEL  
BASE: POWDER COAT, CHROME  
OR SATIN NICKEL  
UPHOLSTERY: ECOPELLE, FABRIC,  
MICROPELLE OR GENUINE LEATHER

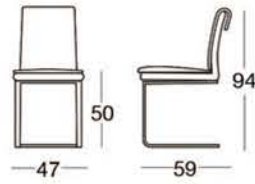

# Viola

DESIGN ITALSTUDIO LAB

C490 CHAIR

FRAME: POWDER COATED STEEL  
SQUARE LEGS: POWDER COAT, CHROME  
OR SATIN NICKEL  
UPHOLSTERY: ECOPELLE, FABRIC,  
MICROPELLE OR GENUINE LEATHER

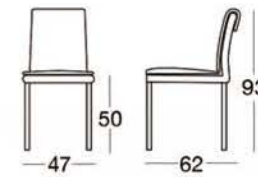



## Filotta

DESIGN ITALSTUDIO LAB

C546 CHAIR

BASE: POWDER COAT SOLID ROUND STEEL

UPHOLSTERY: GENUINE LEATHER, MICROPELLE,  
ECOPELLE OR FABRIC

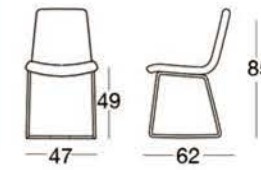

# LANZA

C567 CHAIR

FRAME: POWDER COATING IN VARIOUS COLOURS OR CHROME

UPHOLSTERY: ECOPELLE OR GENUINE LEATHER

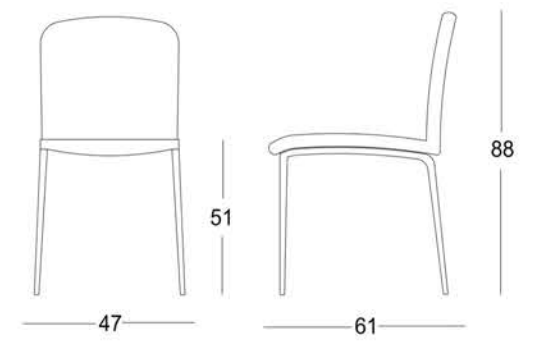

# Venice

DESIGN ITALSTUDIO LAB

**C103V-I** SIDE CHAIR

FRAME: POWDER COAT, CHROME OR SATIN NICKEL  
 UPHOLSTERY: ECOCUOIO LEATHER  
 NOTE: SEAT/BACK ARE REMOVABLE

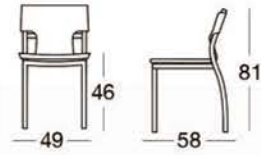

DESIGN ITALSTUDIO LAB

**C103V-AF** ARM CHAIR

FRAME: POWDER COAT, CHROME OR SATIN NICKEL  
 UPHOLSTERY: ECOCUOIO LEATHER  
 ARM PADS: ECOCUOIO LEATHER  
 NOTE: SEAT/BACK ARE REMOVABLE

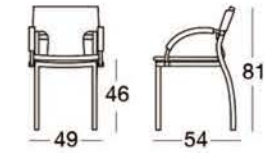

# Stools

---

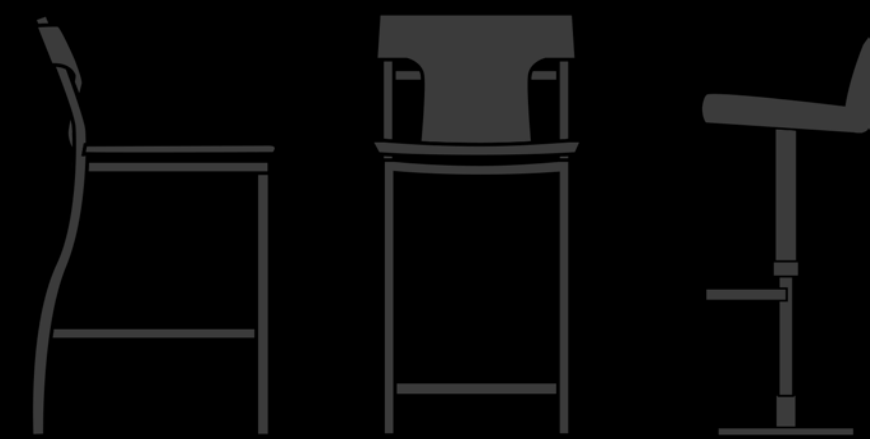



## ANTINA

**C617B** BAR-STOOL

**C617C** COUNTER-STOOL

FRAME: POWDER COATING IN VARIOUS COLOURS

UPHOLSTERY: ECOPELLE OR GENUINE LEATHER

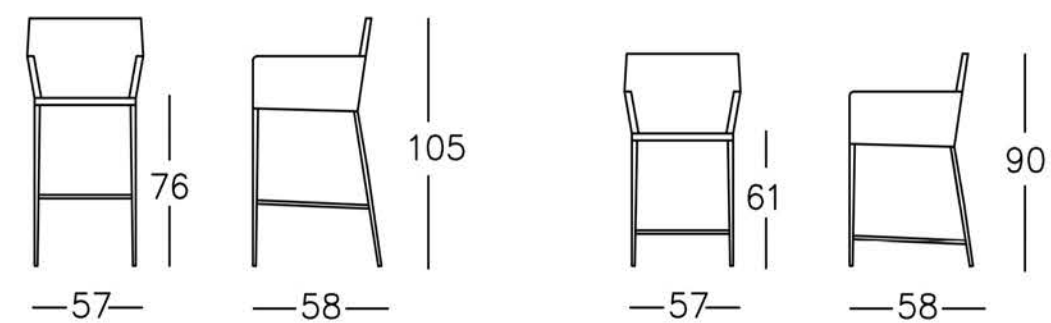



## LOGE

**C625B** BAR-STOOL

**C625C** COUNTER-STOOL

FRAME: POWDER COATING IN VARIOUS COLOURS

UPHOLSTERY: ECOPELLE OR GENUINE LEATHER

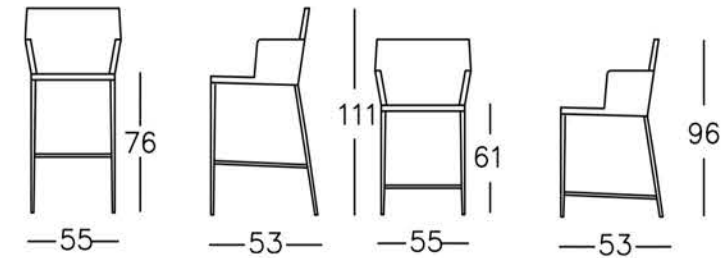

## LOGE

**C625ADJ** HEIGHT ADJUSTABLE STOOL

BASE: MIRROR POLISH STAINLESS STEEL OR  
POWDER COATING IN VARIOUS COLOURS

FRAME: CHROME OR POWDER COATING IN  
VARIOUS COLOURS

UPHOLSTERY: ECOPELLE OR GENUINE LEATHER

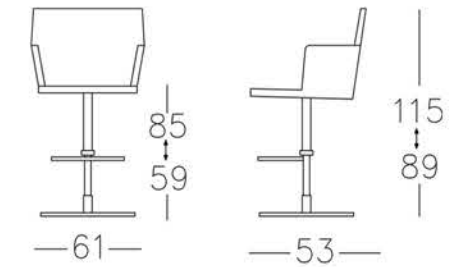

## LORENO

**C623B** C623B BAR-STOOL

**C623C** COUNTER-STOOL

FRAME: POWDER COATING IN VARIOUS COLOURS

UPHOLSTERY: ECOPELLE OR GENUINE LEATHER

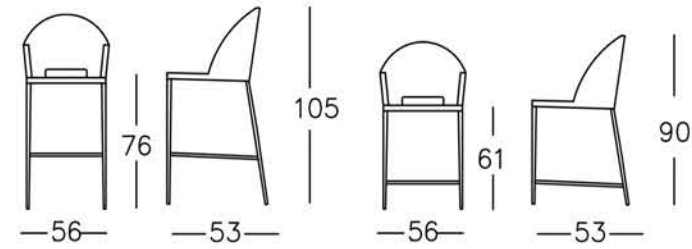

## LORENO

**C623ADJ** HEIGHT ADJUSTABLE STOOL

BASE: MIRROR POLISH STAINLESS STEEL  
OR POWDER COATING IN VARIOUS COLOURS

FRAME: CHROME OR POWDER COATING IN  
VARIOUS COLOURS

UPHOLSTERY: ECOPELLE OR GENUINE LEATHER

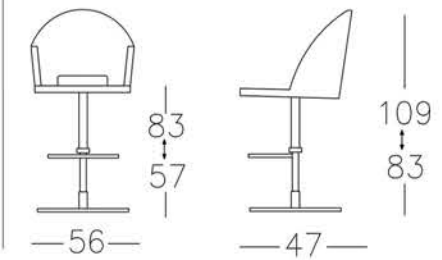

## Maxsoft

DESIGN NEDUMO DESIGN

C498B BAR-STOOL

C498C COUNTER-STOOL

CONIC FRAME: POWDER COAT, SATIN NICKEL OR CHROME.

UPHOLSTERY: GENUINE LEATHER, MICROPELLE, ECOPELLE  
OR FABRIC.

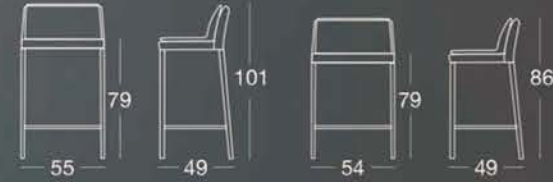

## Maxsoft

DESIGN NEDUMO DESIGN

C498ADJ-RS ADJUSTABLE HEIGHT STOOL

BASE: POWDER COAT OR MIRROR POLISH STAINLESS STEEL

FRAME: POWDER COAT OR CHROME

UPHOLSTERY: GENUINE LEATHER, MICROPELLE, ECOPELLE  
OR FABRIC

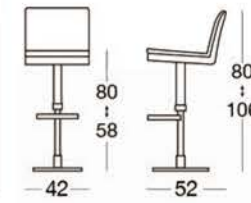



# Filù

DESIGN ITALSTUDIO LAB

C552B BAR-STOOL

C552C COUNTER-STOOL

FRAME/BASE: POWDER COAT ROUND SOLID STEEL

UPHOLSTERY: GENUINE LEATHER, MICROPELLE, ECOPELLE OR FABRIC.

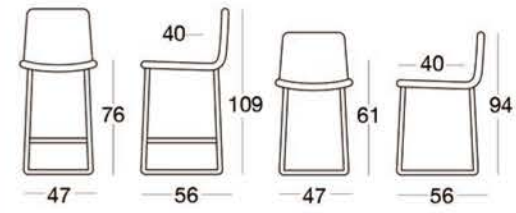



## ANTINA

**C617ADJ** HEIGHT ADJUSTABLE STOOL

BASE: MIRROR POLISH STAINLESS STEEL OR POWDER COATING IN VARIOUS COLOURS

FRAME: CHROME OR POWDER COATING IN VARIOUS COLOURS

UPHOLSTERY: ECOPELLE OR GENUINE LEATHER

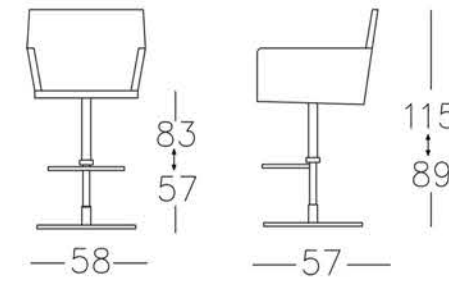

# MARTINO

**C615ADJ** HEIGHT ADJUSTABLE STOOL

BASE: MIRROR POLISH STAINLESS STEEL OR POWDER COATING IN VARIOUS COLOURS

FRAME: CHROME OR POWDER COATING IN VARIOUS COLOURS

UPHOLSTERY: ECOPELLE OR GENUINE LEATHER

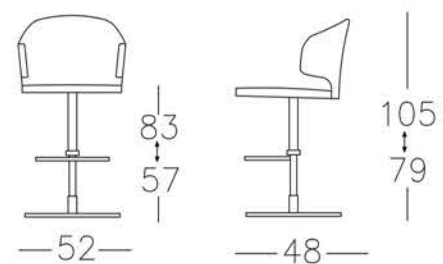

# Anteo

DESIGN NEDUMO DESIGN

C366ADJ HEIGHT ADJUSTABLE STOOL

BASE: POWDER COAT OR MIRROR POLISH STAINLESS STEEL  
FRAME: POWDER COAT OR CHROME  
UPHOLSTERY: GENUINE LEATHER, MICROPELLE, ECOPELLE  
OR FABRIC.

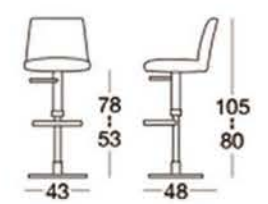

# Alex

DESIGN ISABELLE RIGAL

C475ADJ-TR HEIGHT ADJUSTABLE STOOL

BASE: POWDER COAT OR MIRROR POLISH STAINLESS STEEL

FRAME: POWDER COAT OR CHROME

UPHOLSTERY: GENUINE LEATHER, MICROPELLE, ECOPELLE

OR FABRIC

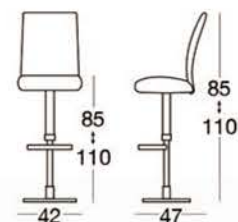

# Elva

DESIGN ITALSTUDIO LAB

**C344G-ADJ-S** HEIGHT ADJUSTABLE STOOL

BASE: POWDER COAT OR MIRROR POLISH STAINLESS STEEL

FRAME: POWDER COAT OR CHROME

UPHOLSTERY: GENUINE LEATHER, MICROPELLE, ECOPELLE  
OR FABRIC

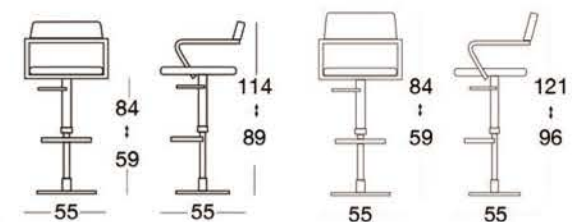



## Brando

DESIGN ITALSTUDIO LAB

**C370ADJ-TR** HEIGHT ADJUSTABLE STOOL

**C370ADJ-A-TR** HEIGHT ADJUSTABLE STOOL W/ARMS

BASE: POWDER COAT OR MIRROR POLISH STAINLESS STEEL

FRAME: POWDER COAT OR CHROME

UPHOLSTERY: GENUINE LEATHER, MICROPELLE, ECOPELLE  
OR FABRIC.

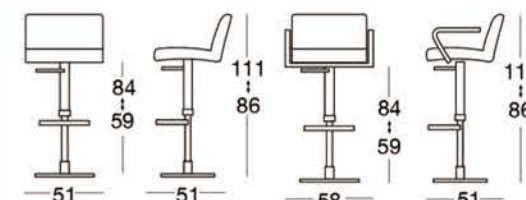

## Marlon

DESIGN ITALSTUDIO LAB

**C888ADJ** HEIGHT ADJUSTABLE STOOL

BASE: POWDER COAT OR MIRROR POLISH STAINLESS STEEL

FRAME: POWDER COAT OR CHROME

UPHOLSTERY: GENUINE LEATHER, MICROPELLE, ECOPELLE  
OR FABRIC.

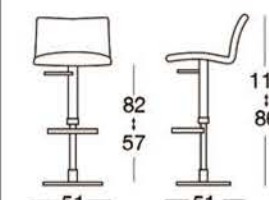



## Dario

DESIGN ITALSTUDIO LAB

**C558ADJ** HEIGHT ADJUSTABLE STOOL

**C558ADJ-A** HEIGHT ADJUSTABLE STOOL W/ARMS

BASE: POWDER COAT OR MIRROR POLISH STAINLESS STEEL

FRAME: POWDER COAT OR CHROME

UPHOLSTERY: GENUINE LEATHER, MICROPELLE, ECOPELLE  
OR FABRIC.

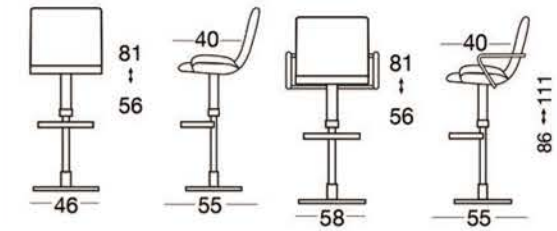



## Venice

DESIGN ITALSTUDIO LAB

C103V-B-I BAR-STOOL

C103V-C-I COUNTER-STOOL

FRAME: POWDER COAT, SATIN NICKEL OR CHROME.

UPHOLSTERY: ECOCUOIO LEATHER

NOTE: SEAT/BACK ARE REMOVABLE

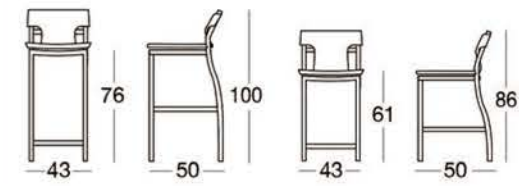

# Emma

DESIGN ITALSTUDIO LAB

C420B BAR-STOOL

C420C COUNTER-STOOL

FRAME: POWDER COATED STEEL

LEGS: LEATHER WRAPPED

FOOT RING: STAINLESS STEEL

UPHOLSTERY: ECOCUOIO LEATHER

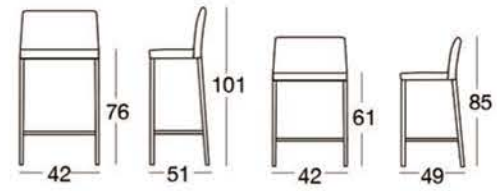

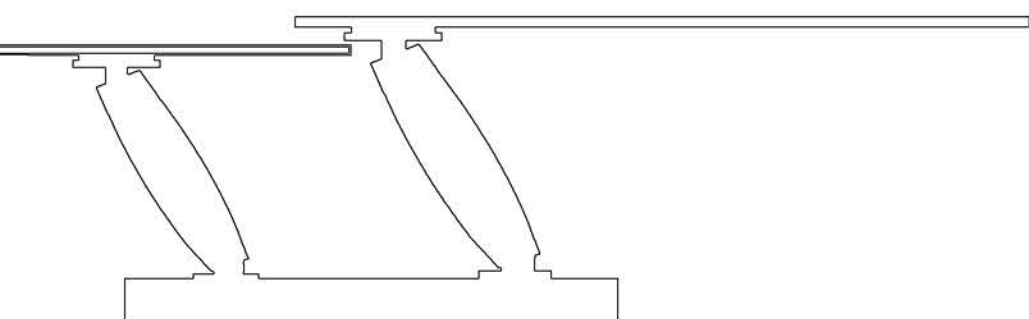

**Occasional**





# Katie

DESIGN ITALSTUDIO LAB



# Katie

DESIGN ITALSTUDIO LAB

0311-F-G SIDEBOARD

STRUCTURE: HIGH GLOSS PAINTED, WOOD VENEER OR  
ECCOUIO LEATHER

LEGS: CHROME

GLASS TOP: CLEAR OR PAINTED MATTE

CERAMIC TOP: MATTE

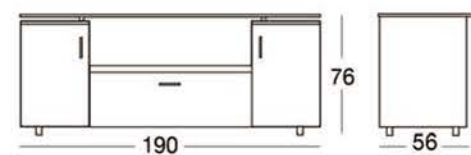
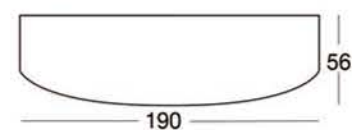



# Athena

DESIGN GIUSY MASTRO



# Athena

DESIGN GIUSY MASTRO

0334-I SIDEBOARD 4 SHUTTERS

0334-II SIDEBOARD 3 SHUTTERS

STRUCTURE: WOOD VENEER

LEGS: MIRROR POLISHED ALUMINUM OR POWDER COATING

GLASS TOP: PAINTED MATTE

CERAMIC TOP: CALA (3 DOOR ONLY) OR MATTE

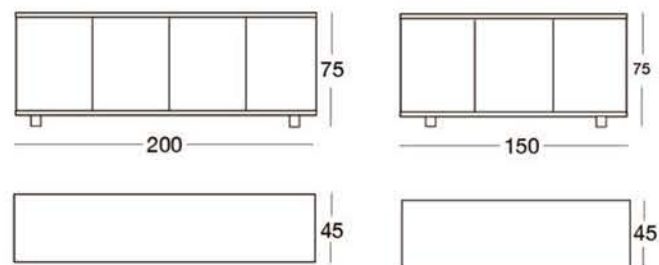



## Ovale

DESIGN ITALSTUDIO LAB

O269/C SIDE TABLE

FRAME: POWDER COAT RECTANGLE STEEL TUBE

CERAMIC TOP: CALA OR MATTE

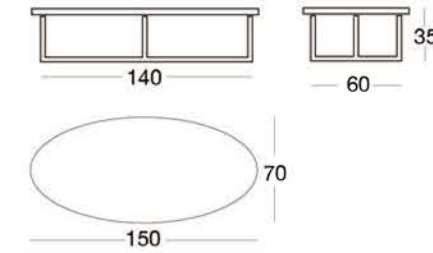



## OTELLO

**0395** COFFEE TABLE

BASE: WOOD IN WALNUT VENEER

TOP: CERAMIC IN VARIOUS COLORS LAMINATED WITH GLASS OR CERAMIC  
WITH 11MM THICKNESS WITHOUT LAMINATED GLASS

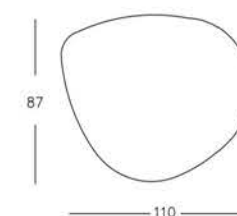



## GOCCIA

T021-I WITH OAK VENEER

T021-II WITH WALNUT VENEER

BASE: WOODEN IN WALNUT VENEER OR OAK VENEER PAINTED IN BLACK

TOP: CLEAR GLASS

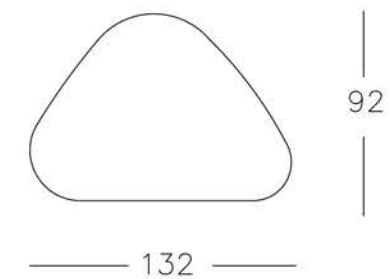
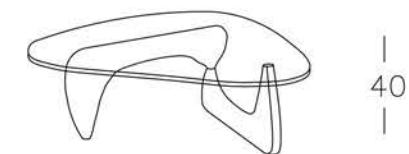



## DORIO

0398 COFFEE TABLE

BASE AND FRAME: POWDER COATING IN VARIOUS COLOURS

TOP: ALL IN CLEAR GLASS OR UPPER TOP WITH CERAMIC  
IN VARIOUS COLOURS AND LOWER TOP WITH CLEAR GLASS

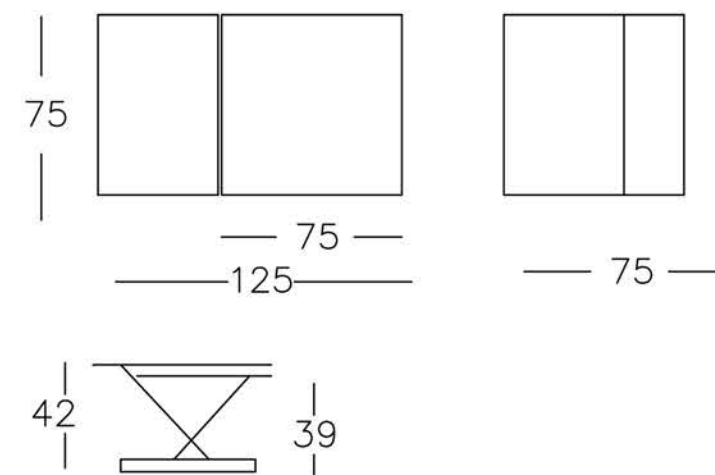

# ORIO

0397 LAMP TABLE

BASE AND FRAME: POWDER COATING IN VARIOUS COLOURS  
TOP: CLEAR GLASS OR CERAMIC IN VARIOUS COLOURS

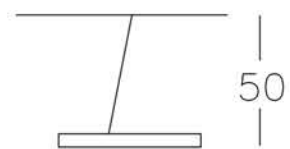
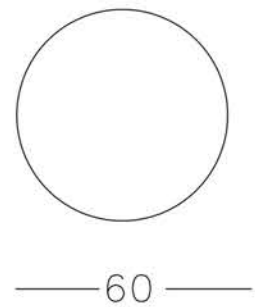

# DORIO

0399 LAMP TABLE

BASE AND FRAME: POWDER COATING IN VARIOUS COLOURS  
TOP: CLEAR GLASS OR CERAMIC IN VARIOUS COLOURS

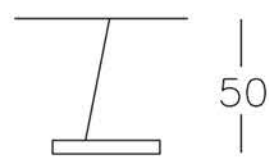
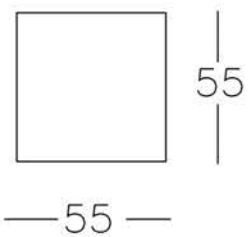

# ORIO

0396 COFFEE TABLE

BASE AND FRAME: POWDER COATING IN VARIOUS COLOURS

TOP: ALL IN CLEAR GLASS OR UPPER TOP WITH CERAMIC

IN VARIOUS COLOURS AND LOWER TOP WITH CLEAR GLASS

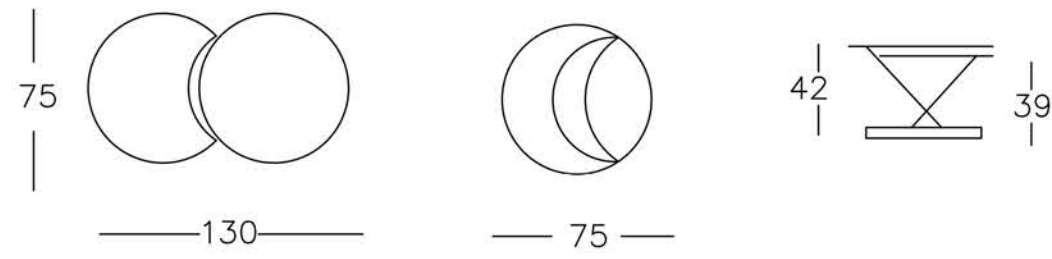

# MARINO

0347 LAMP TABLE

BASE AND FRAME: POWDER COATING IN VARIOUS COLOURS

TOP: CLEAR GLASS OR CERAMIC IN VARIOUS COLOURS

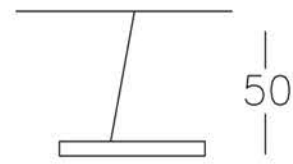
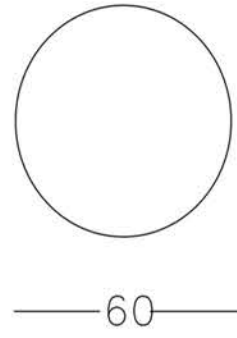

0342 COFFEE TABLE



0343 COFFEE TABLE



0347 LAMP TABLE

# MARINO

## 0343 COFFEE TABLE

BASE AND FRAME: POWDER COATING IN VARIOUS COLOURS

TOP: ALL IN CLEAR GLASS OR UPPER TOP WITH CERAMIC

IN VARIOUS COLOURS AND LOWER TOP WITH CLEAR GLASS

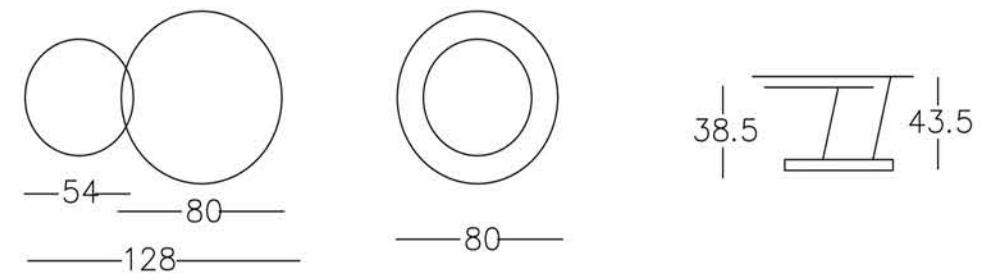

# MARINO

## 0342 COFFEE TABLE

BASE AND FRAME: POWDER COATING IN VARIOUS COLOURS  
 TOP: ALL IN CLEAR GLASS OR UPPER TOP WITH CERAMIC  
 IN VARIOUS COLOURS AND LOWER TOP WITH CLEAR GLASS

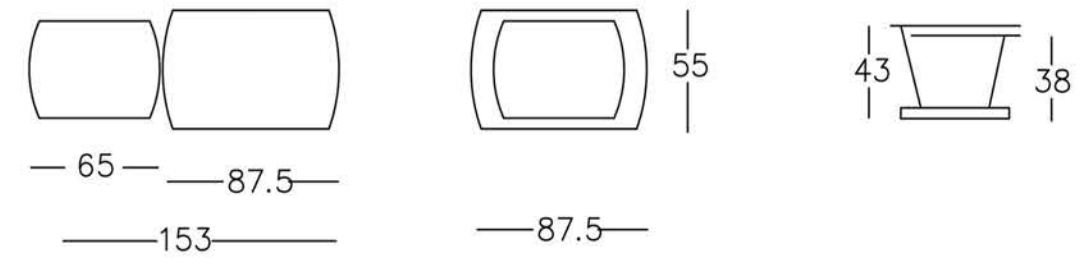

# SAFARI

ST007 SIDE TABLE  
FRAME: POWDER COAT, SATIN NICKEL OR CHROME  
GLASS TOP: CLEAR OR PAINTED MATTE  
CERAMIC TOP: CALA OR MATTE

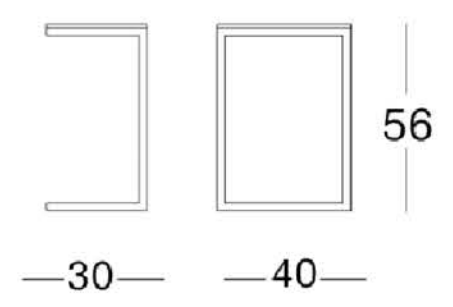



## Ovalino

DESIGN ITALSTUDIO LAB

0354 SIDE TABLE

FRAME: POWDER COAT OVALE TUBE

LEATHER TOP: ECOCUOIO

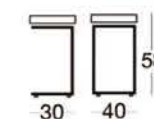





## Treo

DESIGN GIUSY MASTRO

O209/C SIDE TABLE

FRAME: POWDER COAT SOLID FLAT STEEL

CERAMIC: CALA OR MATTE

LEATHER TOP: ECOCUOIO

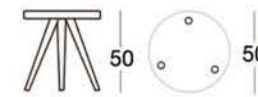

# Duetto

DESIGN NEDUMO DESIGN

O202/C SIDE TABLE

BASE: POWDER COAT STEEL

SUPPORT: CHROME OR POWDER COAT ROUND STEEL

CERAMIC TOP: GALA OR MATTE

GLASS TOP: CLEAR OR PAINTED MATTE

LEATHER TOP: ECOCUOIO

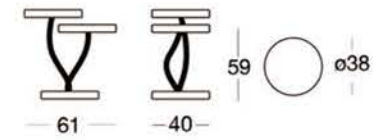



# Zibibbo

DESIGN ITALSTUDIO LAB

0333 NEXT TABLE

FRAME: CHROME OR POWDER COATING SOLID

FLAT STEEL

GLASS TOP: PAINTED MATTE

CERAMIC TOP: CALA OR MATTE

WOOD TOP: VENEER

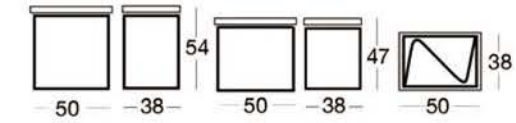

# Finishes

---

## ECOPELLE



V-A05 WENGE



V-A06 COGNAC



V-A10 BEGONIA



V-A14 WHITE



V-A21 IVORY



V-A26 BLACK

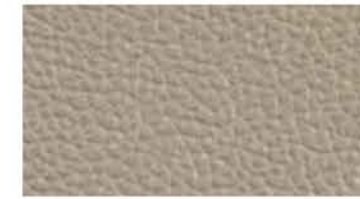

V-A28 LIGHT GREY



V-A29 CAFFELATTE



V-A38 CAPPUCCINO



V-A42 GREY



V-A534 RUST



PL-201 LIGHT GREY



PL-202 LIVER



PL-203 COGNAC



PL-204 ANTRACITE



PL-205 SKYBLUE



TA-301 BLACK



TA-302 WHITE



TA-303 ANTRACITE



TA-305 CHARCOAL



TA-304 TAUPE

# GENUINE LEATHER

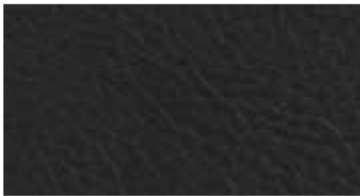

GL2090-1 BLACK



GL2090-2 WHITE

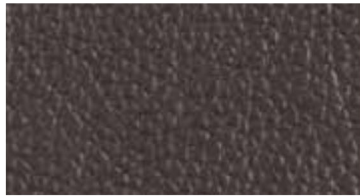

GL2090-3 WENGE



GL2090-4 COGNAC



GL2090-6 GREY

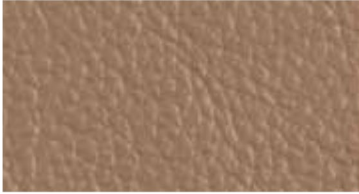

GL2090-8 CAPPUCINO



GL2090-9 CAFFELATTE

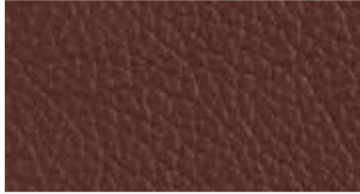

GL2090-11 PRUGNA

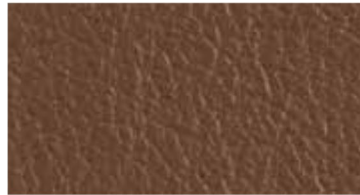

GL2090-12 CHOCOLATE



GL2090-13 VERMIGLIO



GL2090-28 LIGHT GREY



GL2090-16 BLUE AVION

GENUINE SEMIFULL GRAIN LEATHER PIGMENTED. TICKNESS 0.9 TO 1.1 MM IS TYPICALLY FINISHED LIKE AN ANILINE DYE. ALL PROCESSES AND CHEMICALS CONFORM TO EUROPEAN REGULATIONS. FOR DAY TO DAY MAINTENANCE, DUST WITH A SOFT CLOTH. THERE ARE MANY PRODUCTS AVAILABLE ON THE MARKET FOR CLEANING AND CONDITIONING.

# MICROPELLE



MP-100 BLACK

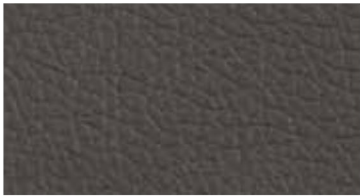

MP-101 GREY

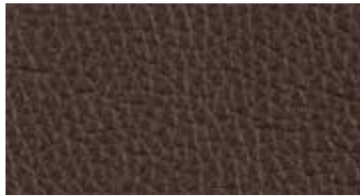

MP-102 WENGÈ

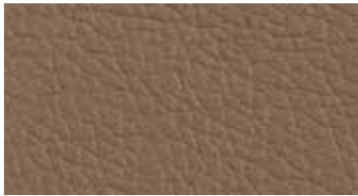

MP-103 CAPPUCINO



MP-104 CAFFELATTE



MP-105 WHITE



MP-106 COGNAC



MP-107 RUST



MP-108 DARK RED

MICROPELLE: POLYURETHANE WITH A MICROFIBER SUPPORT TO CREATE THE MALLEABILITY AND "HAND" OF LEATHER. CLEAN WITH A WATER DAMPENED CLOTH.

# FABRIC



MA-401 BLACK



MA-402 CREME



MA-403 COPPER



MA-404 ANTRACITE



MA-405 CHARCOAL

FABRIC 100% POLYESTER NOT REMOVABLE COVER.

# POWDER COATING



2223 WHITE MATTE



3205 CAPPUCCINO



3233 CHOCOLATE



3302 BLACK COAL

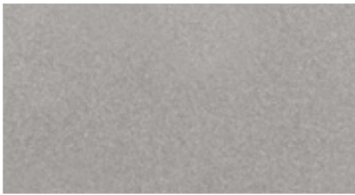

7287 SILVER



7357 GREY



7428 LIGHT GREY



7440 CAFFELATTE

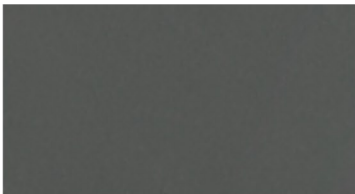

7043 ANTRACITE



3323 MICABLACK



3324 MICAGREY



3325 RUSTY BROWN



801M BLACK

POWDER COAT IS A TREATMENT TO METAL THAT IS APPLIED AS A FREE FLOWING DRY POWDER. THE COATING IS APPLIED ELECTROSTATICALLY AND THEN CURED UNDER HEAT (OVER 200 DEGREES CENTIGRADE) CREATING A HARD, DURABLE FINISH. IT IS ALSO MORE FRIENDLY TO THE ENVIRONMENT AS IT DOES NOT REQUIRE ANY SOLVENTS TO BIND THE FINISH AND DOES NOT RELEASE GASES INTO THE ATMOSPHERE. POWDER COAT ALLOWS A CONSISTENCY ON ALL SURFACES.

# WOOD



W100 EBONY



WS202 BLACK



WS220 WHITE

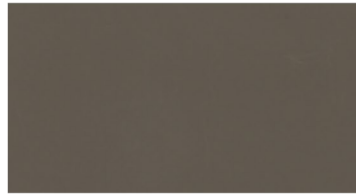

WS224 GREY



WS238 CAPPUCCINO



W347 WALNUT

WOOD VENEER: THIN SLICES OF WOOD ARE GLUED TO MDF TO PRODUCE PANELS FOR CABINETS, DOORS AND TOPS FOR FLAT SURFACES. VENEER IS VERY STABLE, AS THE CHANCES OF WARPING AND SPLITTING ARE REDUCED. THE GLUES PROVIDES ADDED STRENGTH, MAKING THE END RESULT STRONGER THAN NATURAL WOOD. IT IS ALSO FRIENDLY TO THE ENVIRONMENT AS IT REQUIRES 70% LESS ENERGY TO PRODUCE AND HELPS WITH SUSTAINABILITY.

# CERAMIC

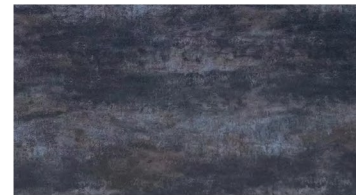

CS03 GRAPHITE

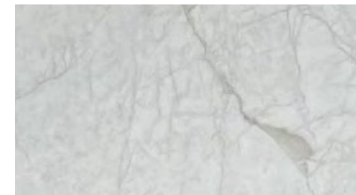

CS04 AVORIO



CS05 TRAVERT

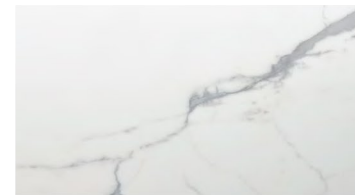

CS07 CARRARA



CS09 SAVOIA



CS09B SAVOIA-B



CS13 BLACK/BROWN



CS14 CARDOS-C



CS15 JADA

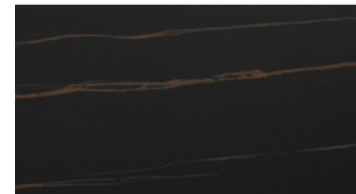

CS18 SCURO 11



CS19 CHIARO 11

THE CERAMIC PANELS IN 3 TO 5 MM ARE LAMINATED TO CLEAR OR SMOKED GLASS TO CREATE PANELS FOR FURNITURE. THE TOPS CAN BE USED FOR EXTENSION TABLES, FIXED TOPS, BUFFET TOPS, ETC AND ARE DURABLE, SCRATCH AND HEAT RESISTANT. THE FINISH HAS THE BEAUTY OF MARBLE WITHOUT THE HEAVY WEIGHT.

# GALVANIC FINISHES



802 CHROME



803 SATIN NICKEL

CHROME: FLAT OR TUBED STEEL IS ELECTROPLATED WITH LAYERS OF NICKEL AND CHROME IN A BATH. THE CHROMED LAYERS ARE HARDENED AND CORROSION RESISTANT.  
SATIN NICKEL: IS ELECTROPLATED WITH NICKEL THEN SATINED THEN CLEAR POWDER COAT PAINT.

ALL THE ITEMS OF ITALSTUDIO COLLECTIONS ARE CREATED WITH THE MOST METICULOUS CRAFTSMANSHIP.  
ANY DIFFERENCES AMONG THE VARIOUS PRODUCTS ARE NOT TO BE CONSIDERED AS IMPERFECTIONS  
BUT RATHER, CHARACTERISTICS OF WORKING BY HAND.  
ITALSTUDIO DUE RESERVES ALL RIGHTS TO MODIFY THE ITEMS IN ORDER  
TO IMPROVE THEIR TECHNICAL AND AESTHETIC ASPECTS.  
THE COLOURS OF THE ITEMS REPRODUCED MAY NOT ALWAYS BE THE SAME AS THE ORIGINAL DUE TO THE PRINTING.

# ITALSTUDIO

THE DESIGN LAB

ITALSTUDIO MFG. LTD.  
ROOM 1201, 12/F., SHANGHAI INDUSTRIAL INVESTMENT BUILDING,  
48-62 HENNESSY ROAD, WANCHAI, HONG KONG

[WWW.ITALSTUDIODESIGN.COM](http://WWW.ITALSTUDIODESIGN.COM) - [INFO@ITALSTUDIODESIGN.COM](mailto:INFO@ITALSTUDIODESIGN.COM)

# **SENSE OF SPACE**

[www.italstudiodesign.com](http://www.italstudiodesign.com)